



Bimetal Thermometers

OUTLINE

This bimetal thermometer uses a bimetal which is composed of two types of metal with different thermal coefficients of expansion and they are wound into a helical form, change according to temperature is transmitted to the indicator, to indicate temperature.

FEATOURES

- Few error according to ambient temperature exists when compared with the liquid filled type.
- This thermometer is safe due to no charged liquid. (no environmental pollution)
- This thermometer is simple in construction and reasonably apriced.
- * When selecting a thermometer, select a thermometer which is normally applied to a temperature range of 30% to 60% of full scale.
Check to confirm that the material of the wetted parts is appropriate to measuring gas or liquid.

SPECIFICATION

Manufacturing temperature range:
-50 ~ 500°C

Dial size:
75DIA., 100DIA., 150DIA. (Small type thermometer 60 DIA.)

Mounting:

T type

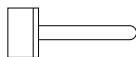

I type

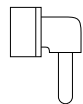

Free angle type

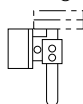

Bulb • Connection material:
304st.st.

Principles • Construction:

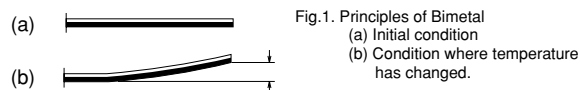

Figure.1



Figure.2

Thermometers

Displacement of the bimetal is transmitted to the pointer

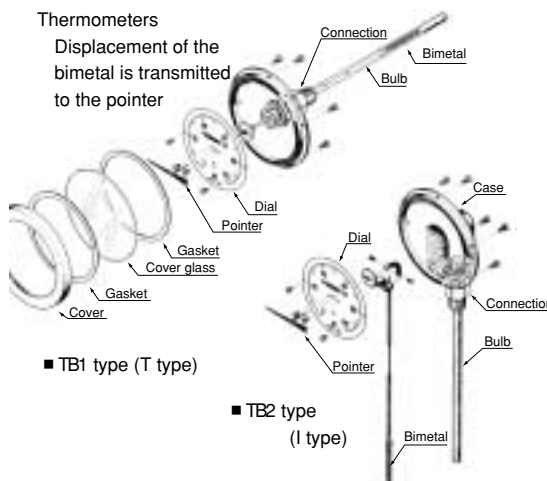

SELECTION GUIDE OF BIMETAL THERMOMETERS

1. Temperature range (Scale range)

- Scale range should be selected to use normally between 30 to 60% of full span.
- When the temperature exceeds the temperature range, it may cause to break the temperature gauge.
For example, if there will be a case that the gauges pass the right on the equator or cold district during transportation, or store them at cold district, it needs careful attention.

Normal using range

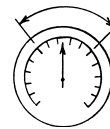

2. Bulb type

Union type

- Standard spec.

	<p>By tightening the fixing screw, it fixed to the connecting thread so that position of bulb does not change.</p>	<p>Maximum allowable working pressure of union type is Less than 200°C → 2MPa Over 200°C → 1MPa (If the pressure is higher than above, thermowell should be provided.)</p>
--	--------------------------------------------------------------------------------------------------------------------	-------------------------------------------------------------------------------------------------------------------------------------------------------------------------------------------------------------------------------------------

Slide type

- At the time when it needs to adjust the bulb position by the changing the position of fluid to be measured in a tank or other vessel.
- At the time when it needs to insert the bulb up to the bottom of thermowell.

	<p>By tightening the gasket with fixing screw, bulb can be fixed at any position.</p>	<p>Maximum allowable working pressure of slide type is 0.3MPa (If the pressure is higher than above, thermowell should be provided.)</p>
--	---------------------------------------------------------------------------------------	---------------------------------------------------------------------------------------------------------------------------------------------------------------

3. Bulb minimum insertion length

- According to type, temperature range and bulb diameter, minimum insertion length is decided.
When placing order or decide the specifications, select a suitable length which is longer than the minimum insertion length to keep the performance.

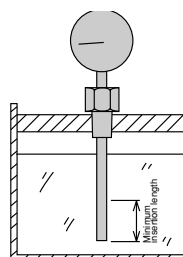

A good example

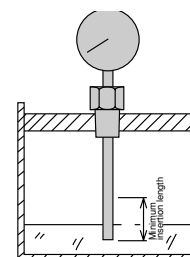

A bad example

4. Thermowell

In the case of following conditions, thermowell should be provided to protect bulb.

- (1) In case of corrosion fluid, thermowell with suitable material is necessary.
- (2) In case of high pressure, necessary to use thermowell suitable for operating pressure.
- (3) In case of fluid with flow, necessary to use thermowell suitable for flow and viscosity.
- (4) In case of fluid leaking out when taking off the thermometer, necessary to use thermowell.
- (5) In case of filled liquid in thermometer is leak out from bulb and it is harmful, necessary to use thermowell.

(1)

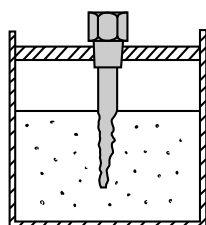

Corrosion

(2)

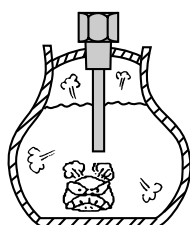

High pressure

(3)

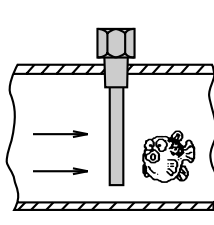

Flow

(4)

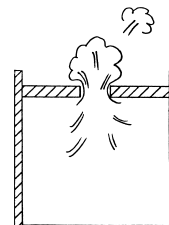

Taking off thermometer

(5)

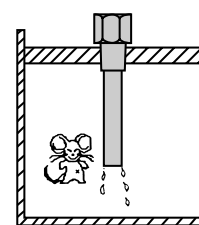

Leakage of filled liquid

BIMETAL THERMOMETERS 1

1. Drip-proof bimetal thermometers

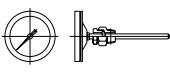
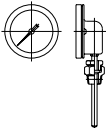
Type	Mounting	Manufacturing range	Dial size (mm)	Model	Case construction
T type		-50 ~ 50°C ↓ 0 ~ 500°C	75 (3")	TB13	Protective class IP43
			100 (4")	TB14	
			150 (6")	TB16	
I type			75 (3")	TB23	
			100 (4")	TB24	
			150 (6")	TB26	

2. Stainless steel (Spray-proof) bimetal thermometers

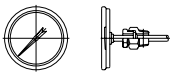
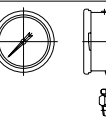
Type	Mounting	Manufacturing range	Dial size (mm)	Model	Case construction
T type		-50 ~ 50°C ↓ 0 ~ 500°C	75 (3")	RB43	Protective class IP65
			100 (4")	RB44	
			150 (6")	RB46	
I type			—	—	
			100 (4")	RB14	
			150 (6")	RB16	

3. Free angle (Spray-proof) bimetal thermometers

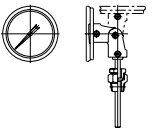
Mounting	Manufacturing range	Dial size (mm)	Model	Case construction
	-50 ~ 50°C ↓ 0 ~ 500°C	100 (4")	TB44	Protective class IP65
		125 (5")	TB45	
		150 (6")	TB46	

4. Small type bimetal thermometers (Indoor-use)

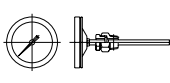
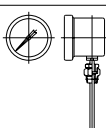
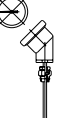
Type	Mounting	Manufacturing range	Dial size (mm)	Model
T type		-50 ~ 50°C ↓ 0 ~ 500°C	60	TB12
I type				TB22
V type				TB32

CONNECTION • BULB SPECIFICATION 1

1. Without thermowell

		Connection	
		Screw type	Flange type
Union type	Slide type	<p>Max. operating pressure : 2MPa (20kgf/cm²) for less than 200°C 1MPa (10kgf/cm²) for 200°C or over</p>	
	Union type	<p>Max. operating pressure : 2MPa (20kgf/cm²) for less than 200°C 1MPa (10kgf/cm²) for 200°C or over</p>	
Slide type	Slide type	<p>(Not available to D=8Dia. of size 150 Dia. and 6 Dia. bulb)</p> <p>Max. operating pressure 0.3MPa (3kgf/cm²)</p>	
	Union type	<p>(Not available to D=8Dia. of size 150 Dia. and 6 Dia. bulb)</p> <p>Max. operating pressure 0.3MPa (3kgf/cm²)</p>	

2. With thermowell

		Connection	
		Screw type	Flange type
Standard type	Slide type		
	Union type		
Double socket type	Slide type	<p>(Not available to D=8 Dia. of size 150 Dia. and 6 Dia. bulb)</p>	
	Union type	<p>(Not available to D=8 Dia. of size 150 Dia. and 6 Dia. bulb)</p>	

CONNECTION • BULB SPECIFICATION2

Connection

	Connecting screw	Flange rating	Note
Standard Connection	R1/2 (PT) , 1/2NPT G1/2B (PF) R3/4 (PT) , G3/4B (PF) (Fixing screw only=W22thread14)	JIS10K20ARF JIS10K25ARF ANSI1B150RF ANSI1B300RF	Other connections except shown left are available. Contact NKS for details.

Graduations

Range °C	Scale division and number entry position	Siz (○ mark is applicable)		
		60•75	100	150
0 ~ 50		○	○	○
0 ~ 100		○	○	○
0 ~ 250		○	○	○
0 ~ 500		○	○	○
0 ~ 60		○	—	—
		—	○	○
0 ~ 120		○	○	○
0 ~ 80		○	○	○
0 ~ 200		○	○	○
0 ~ 400		○	○	○
0 ~ 150		○	—	—
		—	○	○
0 ~ 300		○	—	—
		—	○	○
-10 ~ 50		○	○	○
-20 ~ 100		○	○	○
-30 ~ 50		○	○	○
-50 ~ 50		○	○	○

- Scale angle is 270° ~ 300°

[Example]

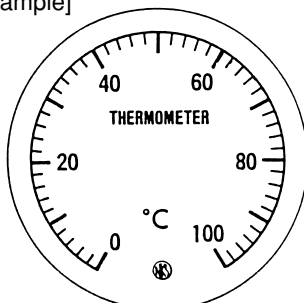

Ground: White

Entry: Black color, red for graduation line and figure of minus parts.

DRIP-PROOF BIMETAL THERMOMETERS 1

TB13 • 14 • 16 T type bimetal

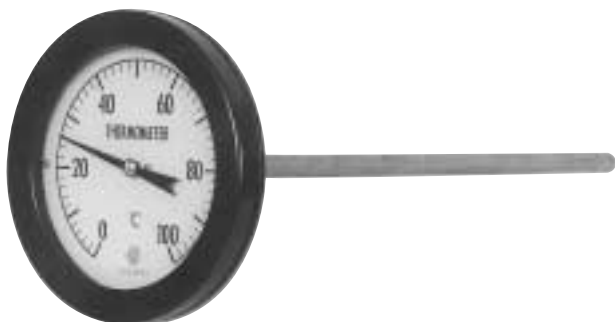

Dimension

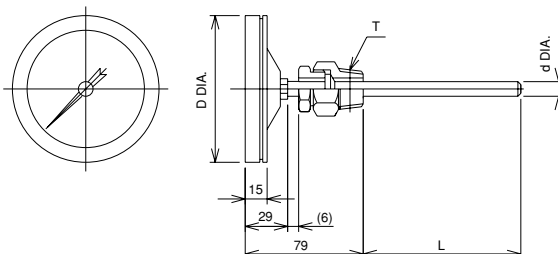

Model	Dial size	D	Weight (L=150)
TB13	75 (3")	96	Approx.380g
TB14	100 (4")	122	Approx.480g
TB16	150 (6")	172	Approx.710g

Specification

Manufacturing range	-50 ~ 50°C → 0 ~ 500°C	
Case	Construction: Drip-proof • Equivalent to IP43, Material: TB13 • 14=Aluminum alloy die casting (ADC12), TB16=Aluminum alloy casting (AC7A), Finishing: Black	
Wetted parts material	Bulb: 304st.st., Connection • Flange: 304st.st.	
Accuracy	Within ±2%F.S.	
Connection	R1/2 (PT), R3/4 (PT), 1/2NPT, G1/2B (PF), G3/4B (PF)	
Flange	JIS10K20ARF, JIS10K25ARF, ANSI1B150RF, ANSI1B300RF	
Connection	Without thermowell	Union type, Slide type
	With thermowell	Double socket union type: R1/2, 1/2NPT (Connection) Double socket slide type: R1/2, 1/2NPT (Connection)
Bulb DIA.	Bulb (d)	6, 8, 10 (Not available to slide type of 6 Dia. and 8 Dia. of TB16)
	Thermowell (d)	12, 15 (Not manufacturing with thermowell for 6mm bulb.)

Range • Bulb DIA. • Bulb length

Range °C	Minimum graduation °C	Standard Bulb DIA. × length (d) × (L) mm	Bulb length (L) mm			Max.
			Minimum insertion length			
			d=6 DIA.	d=8 DIA.	d=10DIA.	
-50 ~ 50	2	10DIA. × 100	105	140 (85)	100 (65)	500 (Up to 300 in case of 6 Dia. bulb)
-30 ~ 50	2	× 150	125	165 (110)	120 (85)	
-20 ~ 100	2	× 100	95	120 (80)	90 (65)	
-10 ~ 50	1	× 150	160	205 (120)	145 (95)	
0 ~ 50	1	× 200	185	240 (140)	165 (110)	
~ 60	1 (2) *	× 150	160	205 (120)	145 (95)	
~ 80	2	× 150	125	165 (110)	120 (85)	
~ 100	2	× 100	105	140 (85)	100 (65)	
~ 120	2	× 100	95	120 (80)	90 (65)	
~ 150	2 (5) *	× 100	80	105 (65)	80 (55)	
~ 200	5	× 100	65	90 (55)	70 (50)	
~ 250	5	× 150	110	150 (85)	110 (65)	
~ 300	5 (10) *	× 100	95	130 (75)	100 (60)	
~ 400	10	× 100	85	110 (70)	80 (55)	
~ 500	10	× 100	75	95 (60)	75 (50)	

* Number shown in () in minimum graduation is applied to TB13.

- In case of 8mm and 10mm dia. bulb, if required more short bulb, available to shorten up to the length in parenthesis.
- Above minimum insertion length is the one for without thermowell. In case of with thermowell, 25mm to be increased to the above length.
- Above length is the minimum necessary length of bulb to be inserted into the fluid to be measured.
- Bulb length should be over the above length and specify 5mm steps.

DRIP-PROOF BIMETAL THERMOMETERS 2

TB23 • 24 • 26 I type bimetal



■ Dimension

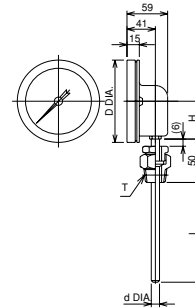

Model	Dial size	D	H	Weight (L=150)
TB23	75 (3")	96	46	Approx.450g
TB24	100 (4")	122	58	Approx.540g
TB26	150 (6")	172	58	Approx.720g

■ Specification

Manufacturing range	-50 ~ 50°C → 0 ~ 500°C	
Case	Construction: Drip-proof • Equivalent to IP43, Material: TB23 • 24=Aluminium alloy die casting (ADC12) , TB26=Aluminium alloy casting (AC7A) , Finishing: Black	
Wetted parts material	Bulb: 304st.st., Connection • Flange: 304st.st.	
Accuracy	Within ±2%F.S.	
Connection	R1/2 (PT) , R3/4 (PT) , 1/2NPT, G1/2B (PF) , G3/4B (PF)	
Flange	JIS10K20ARF, JIS10K25ARF, ANSI1B150RF, ANSI1B300RF	
Connection	Without thermowell	Union type, Slide type
	With thermowell	Double socket union type: R1/2, 1/2NPT (Connection)
		Double socket slide type: R1/2, 1/2NPT (Connection)
Bulb DIA.	Bulb (d)	6, 8, 10 (Not available to slide type of 6 Dia. and 8 Dia. of TB26)
	Termowell (d ₁)	12, 15 (Not manufacturing with thermowell for 6mm bulb.)

■ Range • Bulb DIA. • Bulb length

Range °C	Minimum graduation °C	Standard Bulb DIA. × length (d) × (L) mm	Bulb length (L) mm			Max.
			Minimum insertion length			
			d=6 DIA.	d=8 DIA.	d=10DIA.	
-50 ~ 50	2	10DIA. × 100	105	140 (85)	100 (65)	500 (Up to 300 in case of 6 Dia. bulb)
-30 ~ 50	2	× 150	125	165 (110)	120 (85)	
-20 ~ 100	2	× 100	95	120 (80)	90 (65)	
-10 ~ 50	1	× 150	160	205 (120)	145 (95)	
0 ~ 50	1	× 200	185	240 (140)	165 (110)	
~ 60	1 (2) *	× 150	160	205 (120)	145 (95)	
~ 80	2	× 150	125	165 (110)	120 (85)	
~ 100	2	× 100	105	140 (85)	100 (65)	
~ 120	2	× 100	95	120 (80)	90 (65)	
~ 150	2 (5) *	× 100	80	105 (65)	80 (55)	
~ 200	5	× 100	65	90 (55)	70 (50)	
~ 250	5	× 150	110	150 (85)	110 (65)	
~ 300	5 (10) *	× 100	95	130 (75)	100 (60)	
~ 400	10	× 100	85	110 (70)	80 (55)	
~ 500	10	× 100	75	95 (60)	75 (50)	

* Number shown in () in minimum graduation is applied to TB23.

- In case of 8mm and 10mm dia. bulb, if required more short bulb, available to shorten up to the length in parenthesis.
- minimum insertion length is the one for without thermowell. In case of with thermowell, 25mm to be increased to the above length.
- Above length is the minimum necessary length of bulb to be inserted into the fluid to be measured.
- Bulb length should be over the above length and specify 5mm steps.

RB43 • 44 • 46 T type bimetal



■ Dimension

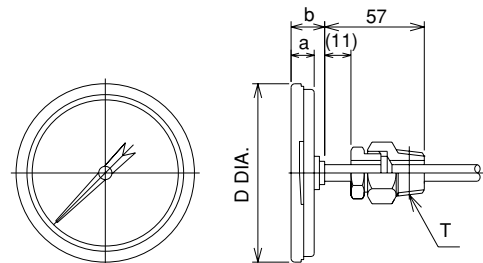

Model	Dial size	D	a	b	Weight (L=200)
RB43	75 (3")	89	18	28	Approx.300g
RB44	100 (4")	116	17	27	Approx.400g
RB46	150 (6")	171	22	32	Approx.1000g

■ Specification

Manufacturing range	-50 ~ 50°C → 0 ~ 500°C	
Case	Construction: Spray-proof • Equivalent to IP65, Material: 304st.st.	
Wetted parts material	Bulb: 304st.st., Connection • Flange: 304st.st.	
Accuracy	Within ±2%F.S.	
Connection	R1/2 (PT) , R3/4 (PT) , 1/2NPT, G1/2B (PF) , G3/4B (PF)	
Flange	JIS10K20ARF, JIS10K25ARF, ANSI1B150RF, ANSI1B300RF	
Connection	Without thermowell	Union type, Slide type
	With thermowell	Double socket union type: R1/2, 1/2NPT (Connection) Double socket slide type: R1/2, 1/2NPT (Connection)
Bulb DIA.	Bulb (d)	6, 8, 10 (Not available to slide type of 6 Dia. and 8 Dia. of RB46)
	Thermowell (D)	12, 15 (Not manufacturing with thermowell for 6mm bulb.)

■ Range • Bulb DIA. • Bulb length

Range °C	Minimum graduation °C	Standard Bulb DIA. × length (d) × (L) mm	Bulb length (L) mm			Max.
			Minimum insertion length			
			d=6 DIA.	d=8 DIA.	d=10DIA.	
-50 ~ 50	2	10DIA. × 100	105	140 (85)	100 (65)	500 (Up to 300 in case of 6 Dia. bulb)
-30 ~ 50	2	× 150	125	165 (110)	120 (85)	
-20 ~ 100	2	× 100	95	120 (80)	90 (65)	
-10 ~ 50	1	× 150	160	205 (120)	145 (95)	
0 ~ 50	1	× 200	185	240 (140)	165 (110)	
~ 60	1 (2) *	× 150	160	205 (120)	145 (95)	
~ 80	2	× 150	125	165 (110)	120 (85)	
~ 100	2	× 100	105	140 (85)	100 (65)	
~ 120	2	× 100	95	120 (80)	90 (65)	
~ 150	2 (5) *	× 100	80	105 (65)	80 (55)	
~ 200	5	× 100	65	90 (55)	70 (50)	
~ 250	5	× 150	110	150 (85)	110 (65)	
~ 300	5 (10) *	× 100	95	130 (75)	100 (60)	
~ 400	10	× 100	85	110 (70)	80 (55)	
~ 500	10	× 100	75	95 (60)	75 (50)	

* Number shown in () in minimum graduation is applied to RB43.

- In case of 8mm and 10mm dia. bulb, if required more short bulb, available to shorten up to the length in parenthesis.
- Above minimum insertion length is the one for without thermowell. In case of with thermowell, 25mm to be increased to the above length.
- Above length is the minimum necessary length of bulb to be inserted into the fluid to be measured.
- Bulb length should be over the above length and specify 5mm steps.

RB14 • 16 I type bimetal



■ Dimension

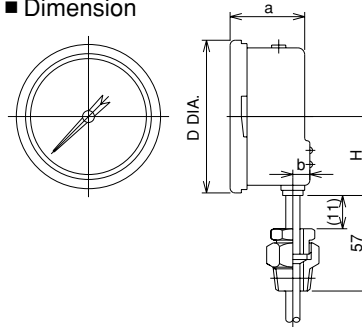

Model	Dial size	D	a	b	H	Weight (L=200)
RB14	100 (4")	116	55	17	56	Approx. 550g
RB16	150 (6")	171	59	21	85	Approx. 1300g

■ Specification

Manufacturing range	-50 ~ 50°C → 0 ~ 500°C	
Case	Construction: Spray-proof • Equivalent to IP65, Material: 304st.st.	
Wetted parts material	Bulb: 304st.st., Connection • Flange: 304st.st.	
Accuracy	Within ±2%F.S.	
Connection	R1/2 (PT) , R3/4 (PT) , 1/2NPT, G1/2B (PF) , G3/4B (PF)	
Flange	JIS10K20ARF, JIS10K25ARF, ANSI1B150RF, ANSI1B300RF	
Connection	Without thermowell	Union type, Slide type
	With thermowell	Double socket union type: R1/2, 1/2NPT (Connection) Double socket slide type: R1/2, 1/2NPT (Connection)
Bulb DIA.	Bulb (d)	6, 8, 10 (Not available to slide type of 6 Dia. and 8 Dia. of RB16)
	Thermowell (d _T)	12, 15 (Not manufacturing with thermowell for 6mm bulb.)

■ Range • Bulb DIA. • Bulb length

Range °C	Minimum graduation °C	Standard Bulb DIA. × length (d) × (L) mm	Bulb length (L) mm			Max. (Up to 300 in case of 6 Dia. bulb)
			Minimum insertion length			
			d=6 DIA.	d=8 DIA.	d=10DIA.	
-50 ~ 50	2	10DIA. × 100	105	140 (85)	100 (65)	500
-30 ~ 50	2	× 150	125	165 (110)	120 (85)	
-20 ~ 100	2	× 100	95	120 (80)	90 (65)	
-10 ~ 50	1	× 150	160	205 (120)	145 (95)	
0 ~ 50	1	× 200	185	240 (140)	165 (110)	
~ 60	1	× 150	160	205 (120)	145 (95)	
~ 80	2	× 150	125	165 (110)	120 (85)	
~ 100	2	× 100	105	140 (85)	100 (65)	
~ 120	2	× 100	95	120 (80)	90 (65)	
~ 150	2	× 100	80	105 (65)	80 (55)	
~ 200	5	× 100	65	90 (55)	70 (50)	
~ 250	5	× 150	110	150 (85)	110 (65)	
~ 300	5	× 100	95	130 (75)	100 (60)	
~ 400	10	× 100	85	110 (70)	80 (55)	
~ 500	10	× 100	75	95 (60)	75 (50)	

- In case of 8mm and 10mm dia. bulb, if required more short bulb, available to shorten up to the length in parenthesis.
- Above minimum insertion length is the one for without thermowell. In case of with thermowell, 25mm to be increased to the above length.
- Above length is the minimum necessary length of bulb to be inserted into the fluid to be measured.
- Bulb length should be over the above length and specify 5mm steps.

FREE ANGLE • BIMETAL THERMOMETERS: SPRAY-PROOF

TB44 • 45 • 46 Free angle bimetal

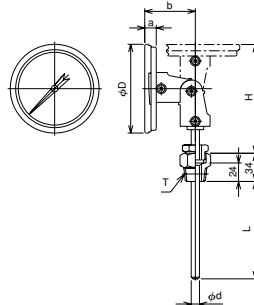

Model	Dial size	D	a	b	H	Weight (L=150)
TB44	100 (4")	116	17	57	117	Approx.550g
TB45	125 (5")	145	17	57	117	Approx.720g
TB46	150 (6")	171	21	61	121	Approx.850g

■ Specification

Manufacturing range	-50 ~ 50°C → 0 ~ 500°C	
Case	Construction: Spray-proof • Equivalent to IP65, Material: 304st.st.	
Wetted parts material	Bulb: 304st.st., Connection • Flange: 304st.st.	
Accuracy	Within ±2%F.S.	
Connection	R1/2 (PT) , R3/4 (PT) , 1/2NPT, G1/2B (PF) , G3/4B (PF)	
Flange	JIS10K20ARF, JIS10K25ARF, ANSI1B150RF, ANSI1B300RF	
Connection	Without thermowell	Union type (Not available to slide type)
	With thermowell	Double socket union type: R1/2, 1/2NPT (Connection)
External zero adjustment mechanism	TB46 (150DIA.) only	
Bulb DIA.	Bulb (d)	6, 8, 10
	Thermowell (d _T)	12, 15 (Not manufacturing with thermowell for 6mm bulb.)

■ Range • Bulb DIA. • Bulb length

Range °C	Minimum graduation °C	Standard Bulb DIA. × length (d) × (L) mm	Bulb length (L) mm			Max. (Up to 300 in case of 6 Dia. bulb)
			Minimum insertion length			
			d=6 DIA.	d=8 DIA.	d=10DIA.	
-50 ~ 50	2	10DIA. × 100	105	140	100	500 (Up to 300 in case of 6 Dia. bulb)
-30 ~ 50	2	× 150	125	165	120	
-20 ~ 100	2	× 100	95	120	90	
-10 ~ 50	1	× 150	160	205	145	
0 ~ 50	1	× 200	185	240	165	
~ 60	1	× 150	160	205	145	
~ 80	2	× 150	125	165	120	
~ 100	2	× 100	105	140	100	
~ 120	2	× 100	95	120	90	
~ 150	2	× 100	80	105	80	
~ 200	5	× 100	65	90	70	
~ 250	5	× 150	110	150	110	
~ 300	5	× 100	95	130	100	
~ 400	10	× 100	85	110	80	
~ 500	10	× 100	75	95	75	

- Above minimum insertion length is the one for without thermowell. In case of with thermowell, 25mm to be increased to the above length.
- Above length is the minimum necessary length of bulb to be inserted into the fluid to be measured.
- Bulb length should be over the above length and specify 5mm steps.

SMALL TYPE BIMETAL THERMOMETERS: INDOOR USE

TB12 (0Ttype) • TB22 (Itype) • TB32 (Vtype) /60DIA.

■ TB12 (Ttype)

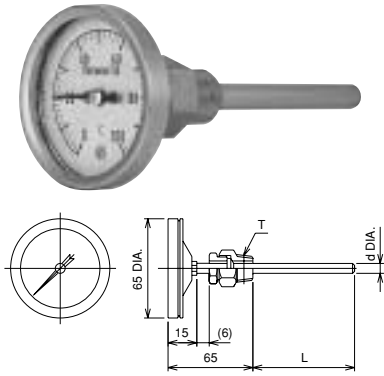

Weight Approx. 220g (L=150)

■ TB22 (Itype)

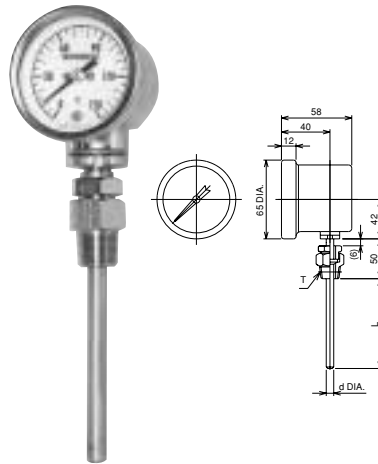

Weight Approx. 340g (L=150)

■ TB32 (Vtype)

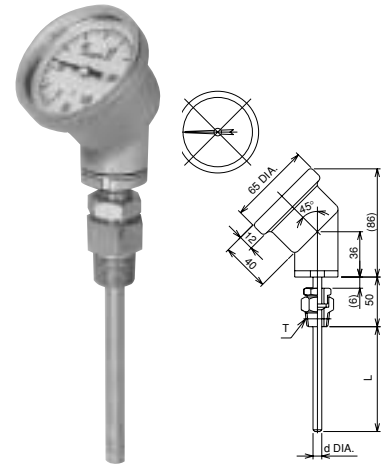

Weight Approx. 400g (L=150)

■ Specification

Manufacturing range	-50 ~ 50°C → 0 ~ 500°C	
Case	Construction: Indoor use, Material: SPCC, Finishing: Ni-gilt	
Wetted parts material	Bulb: 304st.st., Connection • Flange: 304st.st.	
Accuracy	Within ±2%F.S.	
Connection	R1/2 (PT) , R3/4 (PT) , 1/2NPT, G1/2B (PF) , G3/4B (PF)	
Flange	JIS10K20ARF, JIS10K25ARF, ANSI1B150RF, ANSI1B300RF	
Connection	Without thermowell	Union type (Not available to slide type)
	With thermowell	Double socket union type: R1/2· 1/2NPT (Connection)
Bulb DIA.	Bulb (d)	6, 8, 10
	Termowell (d ₁)	12, 15 (Not manufacturing with thermowell for 6mm bulb.)

■ Range • Bulb DIA. • Bulb length

Range °C	Minimum graduation °C	Standard Bulb DIA. × length (d) × (L) mm	Bulb length (L) mm			Max.
			Minimum insertion length			
			d=6 DIA.	d=8 DIA.	d=10DIA.	
-50 ~ 50	2	10DIA. × 100	105	140	100	500 (Up to 300 in case of 6 Dia. bulb)
-30 ~ 50	2	× 150	125	165	120	
-20 ~ 100	2	× 100	95	120	90	
-10 ~ 50	1	× 150	160	205	145	
0 ~ 50	1	× 200	185	240	165	
~ 60	2	× 150	160	205	145	
~ 80	2	× 150	125	165	120	
~ 100	2	× 100	105	140	100	
~ 120	2	× 100	95	120	90	
~ 150	5	× 100	80	105	80	
~ 200	5	× 100	65	90	70	
~ 250	5	× 150	110	150	110	
~ 300	10	× 100	95	130	100	
~ 400	10	× 100	85	110	80	
~ 500	10	× 100	75	95	75	

- Above minimum insertion length is the one for without thermowell. In case of with thermowell, 25mm to be increased to the above length.
- Above length is the minimum necessary length of bulb to be inserted into the fluid to be measured.
- Bulb length should be over the above length and specify 5mm steps.

CONNECTION • BULB SPECIFICATION

■ Connection and dimension

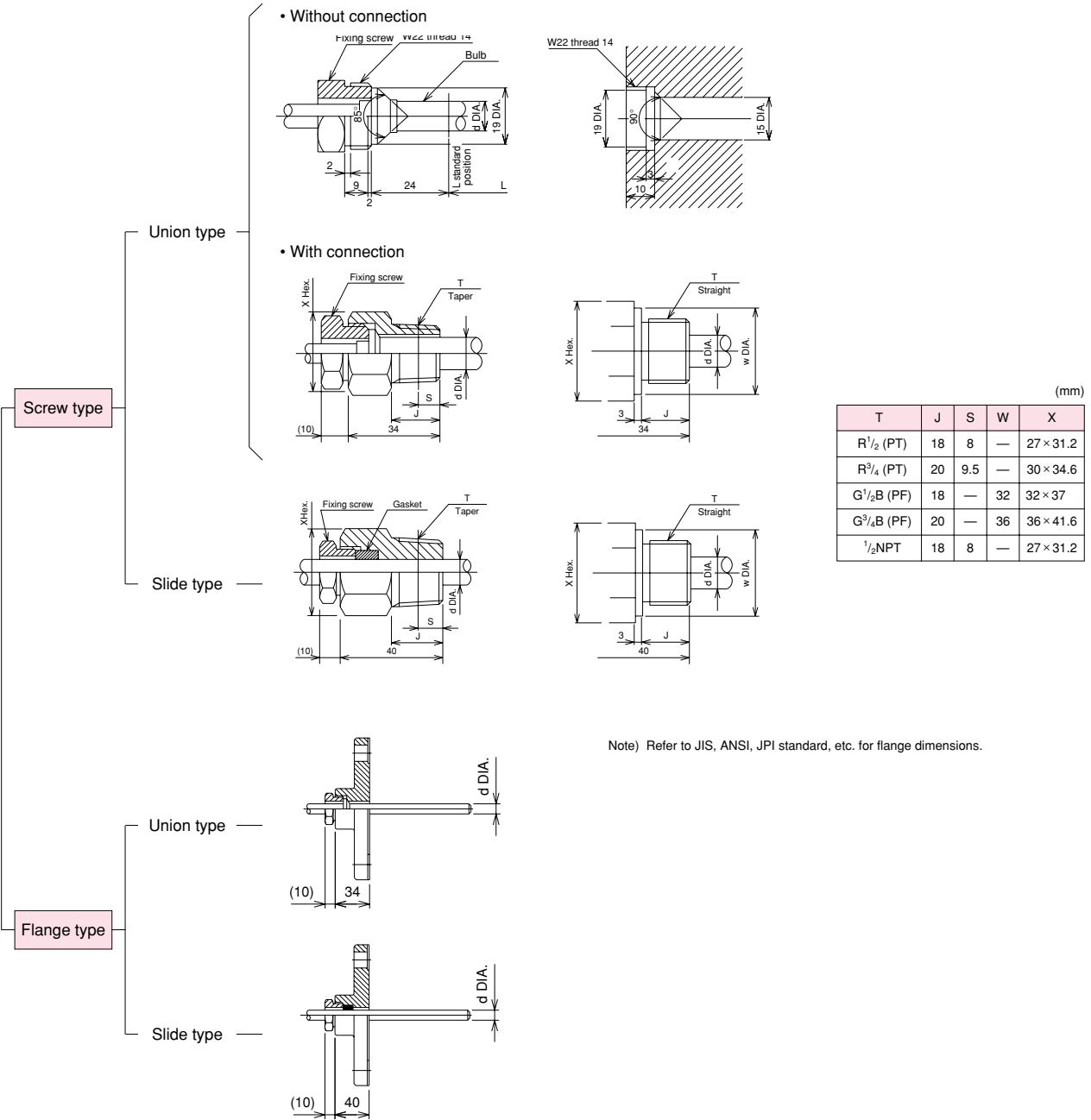

■ Relation of bulb DIA., connection and connection, flange

Bulb DIA. (d)	Connection		T		
	Union type	Slide type	Connection ¹ / ₂	³ / ₄	Flange JIS, ANSI, JPI
6DIA.	○	—	○	○	○
8DIA.	○	* ○	○	○	○
10DIA.	○	○	○	○	○

* 8mm dia. bulb of slide type is only available with 150mm dia.
But not available with free angle type.

Type No. Constitution

Please specify Type No., each specification and temperature range when ordering.

Note: For this Model, there is no applicable item for the figures X, but please specify X when ordering.

Mdel	Mounting • Size
TB13	Drip-proof, Ttype, 75DIA.
TB14	Drip-proof, Ttype, 100DIA.
TB16	Drip-proof, Ttype, 150DIA.
TB23	Drip-proof, I type, 75DIA.
TB24	Drip-proof, I type, 100DIA.
TB26	Drip-proof, I type, 150DIA.
RB43	Spray-proof, Ttype, 75DIA.
RB44	Spray-proof, Ttype, 100DIA.
RB46	Spray-proof, Ttype, 150DIA.
RB14	Spray-proof, I type, 100DIA.
RB16	Spray-proof, I type, 150DIA.
TB44	Spray-proof free angle, 100DIA.
TB45	Spray-proof free angle, 125DIA.
TB46	Spray-proof free angle, 150DIA.
TB12	Indoor use, Ttype, 60DIA.
TB22	Indoor use, I type, 60DIA.
TB32	Indoor use, V type, 60DIA.

1 Thermowell inner connection

0	Without thermowell
1	With thermowell: W22 thread14 (Standard)
2	With thermowell: R ¹ / ₂ double socket
3	With thermowell: 1/2NPT double socket
4	With thermowell: G ¹ / ₂ double socket
5	With thermowell: R ³ / ₄ double socket

Please refer to next page for thermowell. (SW□□)

2 Connection

0	Union type/Fixed type
1	Slide type/Fixed type*

* Slide type is not manufacturing for all model of 6mm dia. bulb and also 8mm dia. bulb of 150mm dial size.
Also not available with free angle type and small type.

3 Connection

0	R ¹ / ₂
1	R ³ / ₄
2	1/2NPT
3	G ¹ / ₂ B
4	G ³ / ₄ B
5	JIS10K20ARF
6	JIS10K25ARF
7	ANSI1B150RF
8	ANSI1B300RF
A	Fixing screw (W22 thread 14) union type only

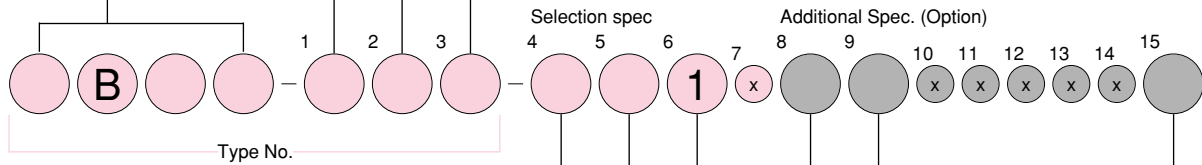

4 Range (°C)

1	0 ~ 50, 60, 80, 100, 120, 150, 200, 250, 300
2	0 ~ 400, 500
3	-10 ~ 50, -20 ~ 100, -30 ~ 50, -50 ~ 50

Please specify range & unit.

5 Bulb DIA.

0	6DIA., L=300 (max.)
1	8DIA., L=500 (max.)
2	10DIA., L=500 (max.)

6 Bulb length (mm) L dimension

1	From min. insertion length to 500mm (Up to 300mm for 6mm bulb.)
---	-----------------------------------------------------------------

Specify bulb length 5m/m stems.

15 Document

0	Nil
1	Please specify your requirement. Drawing one sheet, Instruction manual, Inspection procedure, Mill sheet, Test report.

9 Other additional spec.

0	Nil
1	Please specify your requirement. Case finishing, Dual scale with (°F) Connection 316 st.st.option. External zero adjustment (TB46)

8 Treatment

0	Nil
1	Use no oil
2	Use no water
3	Use no oil & water

THERMOWELL SPECIFICATION

■ Connection parts and dimension

■ Thermowell type, Size

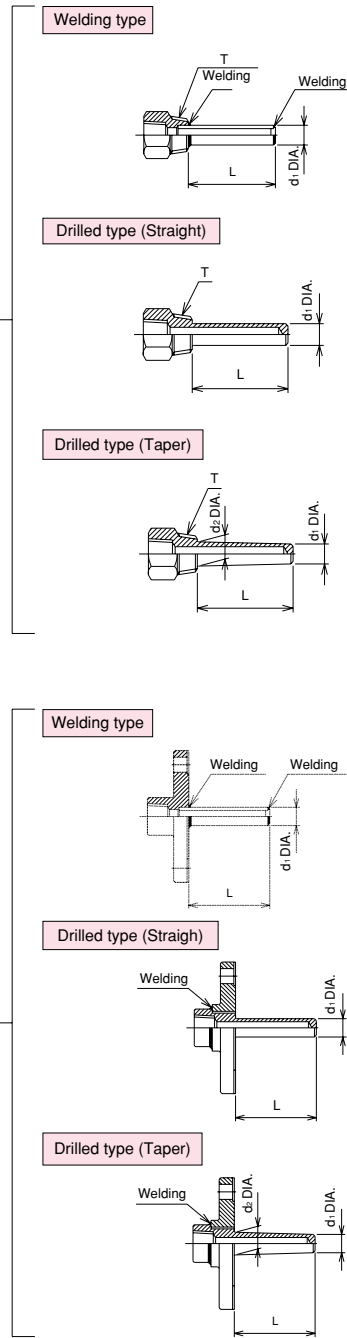
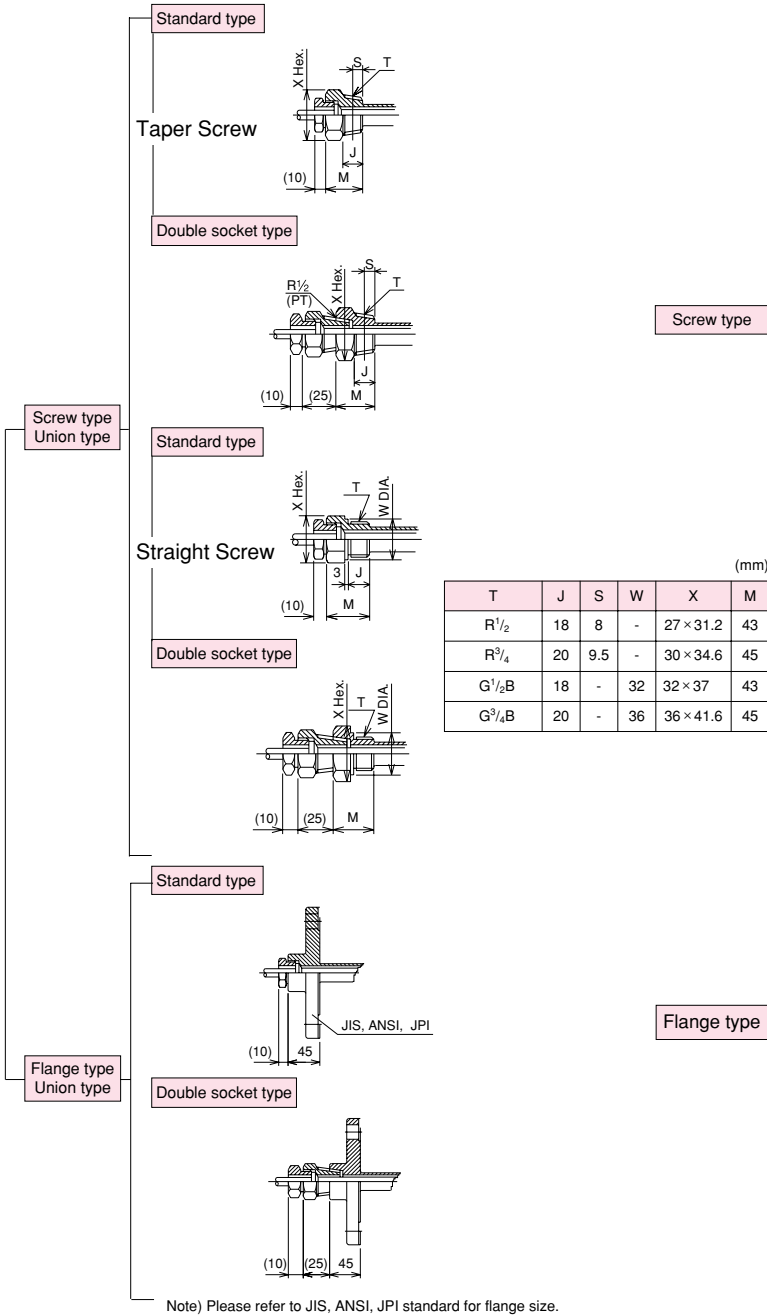

■ Relation of Thermowell and bulb.

Thermo-well	Out dia (d1 DIA.)	12		15	
	type	Drilled type	Welding type	Drilled type	Welding type
Bulb	Inner dia (d2 DIA.)	8.5	8.5	10.5	11
	d DIA.	8	8	10	10

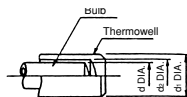

■ Thermowell material 1

304 st.st., 316 st.st., 316 L st.st., Titanium, Hastelloy-B, and Monel-metal are available.
 Coating is available with followings. Rubber, Kel-F, Teflon, Lead or Glass
 Thermowell with coating is flange type only.

Type No. Constitution Please specify Type No., each specification and temperature range when ordering.

(Note: For this Model, there is no applicable item for the figures X, but please specify X when ordering.)

