



## Process Applications Pressure/Diff.Pressure Transmitters

### OUTLINE

This is a (differential)pressure transmitter which is of job site type and has been designed for process applications. Two types exist: the general application type and pressure resistant, explosion preventive type. So, selection of either type according to a utilization environment is possible.

### MODEL CONSTITUTION

	General process use	Explosion-proof purpose (Explosion-protected construction)
Pressure	KH41	KD41 (Exd II BT4)
	KH43	KD43 (Exd II BT4)
Differential pressure	KH45	KD45 (Exds II B+H <sub>2</sub> T4)

### FEATURE

#### Pressure transmitter

(KH41 • 43, KD41 • 43)

- Because of semiconductor strain gauge application to the pressure sensing portion, excellent durability and stability is assured.
- Because it adopts high corrosion resistance metal diaphragm in wetted parts, it is superior in corrosion resistance, and is usable in wide application even in which of gas and liquid.
- As it isn't influenced transceiver, electromagnetic interference countermeasures is bestowed.

#### Differential pressure transmitter

(KH45, KD45)

- It adopts precision capacitance type sensor processed by micro-machining technology.
- It is possible to change a range. (1: 5)
- Field indication is available. (LCD 3 1/2 digit)
- Zero point shift for plus or minus is easily available. (Zero suppression, Zero elevation)

### SPECIFICATION 1

#### Fluid:

Gas or liquid

\* When the fluid is high viscosity, diaphragm seal type is also available.

#### Operating condition:

KH4□ (General process use)

Under the normal condition, where there is no inflammable gas or liquid which cause the ignition or explosion

KD4□ (Explosion-protected construction)

Hazardous area. The details refer to explanation column of explosion-protected construction.

#### Mounting:

Steam mounting, Surface mounting, 2B pipe mounting

#### Connection:

Rc 1/2 (PT female), Rc 1/4 (PT female)

#### Wetted parts material:

KH41 SCS14 + 316 st.st.

KH43 316 st.st. + Co-Ni alloy

KH45 Diaphragm: 316L st.st. Flange: SCS14

#### O-ring: NBR (Standard)Gasket: Teflon

KD41 SCS14 + 316 st.st. + 304 st.st.

KD43 SCS14 + 316 st.st. + Co-Ni alloy + 304 st.st.

KD45 Diaphragm: 316L st.st. Flange: SCS14

#### O-ring: NBR (Standard)Gasket: Teflon

## SPECIFICATION 2

### Range:

Pressure (K□41 • 43)

-5 ~ +5 → -50 ~ +50kPa

(-500 ~ +500 → -5000 ~ +5000mmH<sub>2</sub>O)

-0.1 ~ 0 → -0.1 ~ 2MPa (-1 ~ 0 → -1 ~ 20kgf/cm<sup>2</sup>)

0 ~ 5kPa → 0 ~ 50MPa (0 ~ 500mmH<sub>2</sub>O → 0 ~ 500kgf/cm<sup>2</sup>)

Differential pressure (K□45)

1.2 ~ 6 → 20 ~ 100kPa (120 ~ 600 → 2000 ~ 10000mmH<sub>2</sub>O)

### Power source:

12 ~ 32V DC (Standard 24V DC)

17 ~ 32V DC (With indicator) (K□45 only)

### Output :

4 ~ 20mA DC (Two wire system)

### Load resistance:

600Ω max. (In 24V DC)

400Ω max. (With indicator, 24V DC) (K□45 only)

### Withstand voltage:

250V AC 1 minute

### Max. allowable pressure (K□41 • 43)

150% of rated pressure

### Operating pressure range (K□45)

-0.05 ~ 10MPa (-0.5 ~ 100kgf/cm<sup>2</sup>)

### Operating temperature:

KH4□ -30 ~ 80°C (But fluid should not be frozen)

KD4□ -20 ~ 60°C (But fluid should not be frozen)

### Storage temperature:

KH4□ -30 ~ 80°C

KD4□ -30 ~ 70°C

### Operating humidity limits:

30 ~ 95%RH (Prohibited dew condensation)

### Accuracy:

K□41 • 43 ±0.25 % F.S. or ±0.5 % F.S

K□45 ±0.5%F.S.

(Include linearity, hysteresis, repeatability)

### Temperature coefficient:

K□41 • 43 ±0.025%F.S./°C (Zero)

±0.025%F.S./°C (Span)

(-20 ~ 70°C)

K□45 Zero shift: ±1.0%/50°C at max. span.

### Synthesis shift: (It contains span shift and zero point)

±2%/50°C (Contains zero point and span shift.)

### Outlet for electric wire:

KH41 • 43 PF1/2

KH45 G1/2

KD41 • 43 • 45 Packing type cable gland

(Out dia of applicable cable is 7mm ~ 12mm.

8mm ~ 12mm for KD45.)

### Case material:

ADC12 (Alumi-dia casting)

### Construction

K□41 Splash-proof (IP54)

K□43 • 45 Jet-proof (IP55)

But pressure range 2 MPa or less is splash-proof (IP54) (K□43 only)

### Weight:

Approx. 0.85kg ~ Approx. 5.8kg

## DIFFERENTIAL PRESSURE TRANSMITTER

### Display:

LCD digital display Max.1999 (Standard 0.0 ~ 100.0%)

Operating temperature KH45 -20 ~ 70°C

KD45 -20 ~ 60°C

Storage temperature -20 ~ 70°C

Accuracy ±(0.2% of rdg+1digit)

### Influence of over-pressure:

Zero point shift at max. span after adding 10MPa

(100kgf/cm<sup>2</sup>)pressure: ±0.5%

### In fluence of static pressure:

When the static pressure is 10MPa (100kgf/cm<sup>2</sup>),

Zero point shift at max. span is ±0.5%

### Zero transition:

Available between-100 to + 80% of max. span.

## WIRING

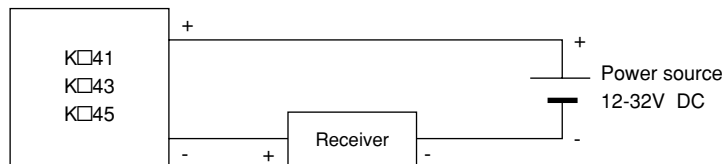

(Receiver example: Our GC82 digital indicator or GC94 digital meter relay, etc.)

## RANGE OF LOAD RESISTANCE

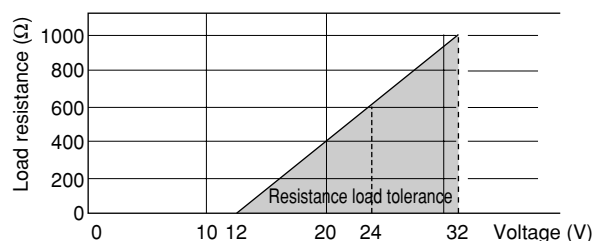

# EXPLOSION-PROTECTED CONSTRUCTION

Type approval for explosion-proof:

It acquires a technical standard adjusted in international standard IEC by the Ministry of Labor notification and the national authorization on the basis of new explosion proof guide.

Type name	Type Approval number
KD41	No.C10599
KD43	No.C10598
KD45 Without indicator	No.C10497
KD45 With indicator	No.C10498

KD41 • 43 Explosion-protected construction Exd II BT4  
 KD45 Explosion-protected construction Exds II B+H<sub>2</sub>T4

Explosion-protected construction:

Explosion protected-construction is a totally enclosed construction such that even if the explosive gas explodes inside the container, the container withstands the force of the explosion and there is no danger of ignition of external explosive gases.

As for our pressure • differential pressure transmitter produced based on this policy, use can have combustible gases or steam of combustibility liquid in pressure measurement at a place with existing fear in a factory, other business office.

Exd II BT4, Exds II B + H<sub>2</sub> T4:

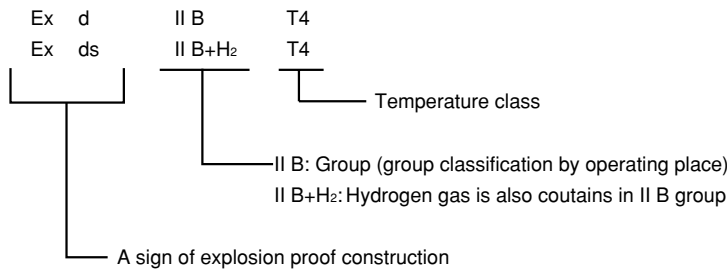

Group classification

A kind of explosion proof electrical instrument and apparatus is classed in group I and group II by a place to be used. KD41 • 43 and KD45 belongs to group II, and comes under machinery using it in a factory except hazardous location of the mine or hazardous location of business office.

Applicable group and classification of gas or steam.

Classification of gas or steam	Applicable group		
	II A	II B	II C
A	II A	II B	II C
B	—	II B	II C
C	—	—	II C

Ignition point of gas or steam which T4 can apply.

Ignition point of gas or steam	Applicable temperature class					
	T1	T2	T3	T4	T5	T6
Higher than 450 g	T1	T2	T3	T4	T5	T6
Higher than 300 g	—	T2	T3	T4	T5	T6
Higher than 200 g	—	—	T3	T4	T5	T6
Higher than 135 g	—	—	—	T4	T5	T6
Higher than 100 g	—	—	—	—	T5	T6
Higher than 85 g	—	—	—	—	—	T6

Example of applicable gas or steam.

Temperature class Group	T1	T2	T3	T4	T5	T6
	II A	Acetone Ammonia Carbon monoxide Ethane Acetic acid Ethyl acetate Toluene Propane Benzene Methanol Methane	Ethanol 1- butanol Butane	Hexane	Acetaldehyde	
II B		Ethylene Ethylenoxide		Ethyl methyl Ether		
II C	Hydrogen*	Acetylene			Carbon bisulfide	Nitric acid ethyl

\* Hydrogen can be available by only KD45.

# DIMENSION 1

## KH41 Pressure Transmitter

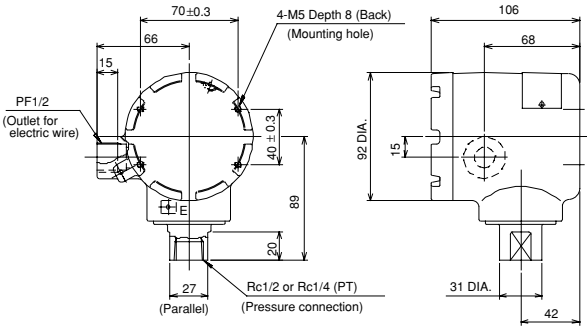

Stem mounting

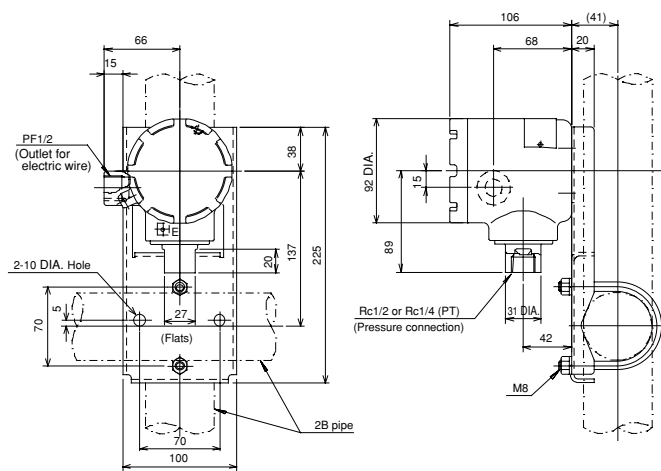

2B pipe mounting

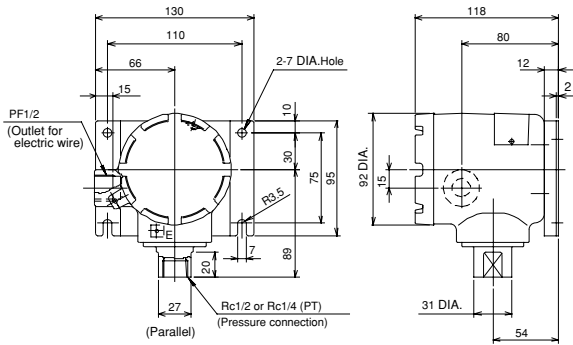

Surface mounting

## KH43 Pressure Transmitter

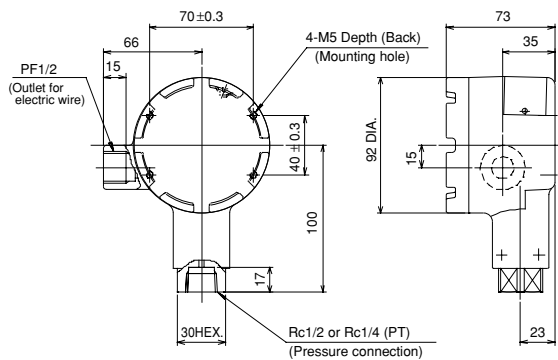

Stem mounting

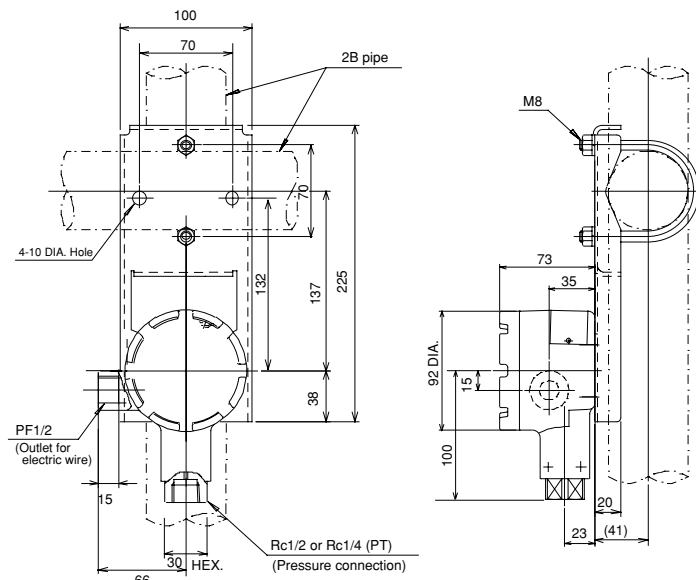

2B pipe mounting

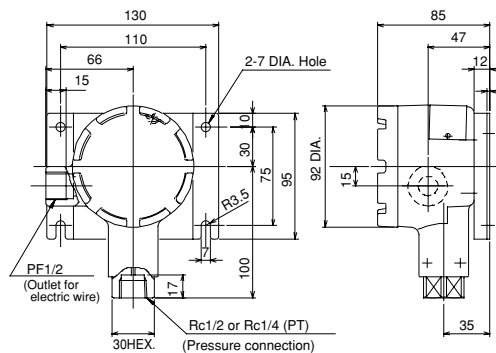

Surface mounting

## DIMENSION 2

### KH45 Differential pressure transmitter

#### Without indicator

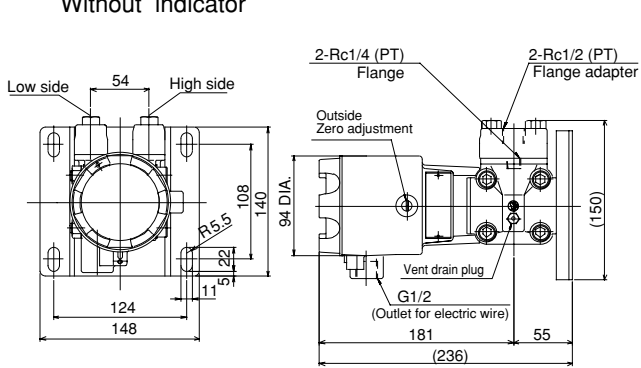

Surface mounting

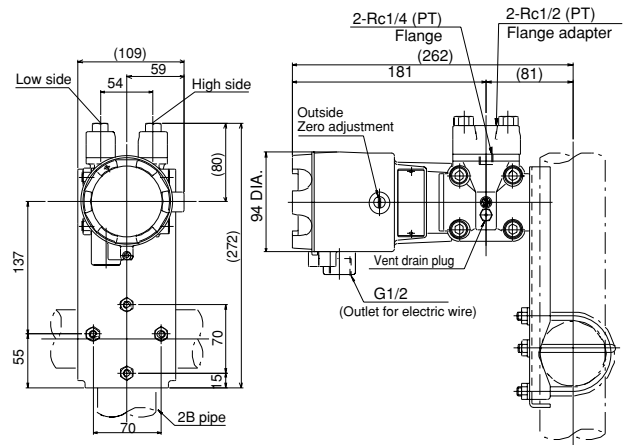

2B pipe mounting

#### With indicator

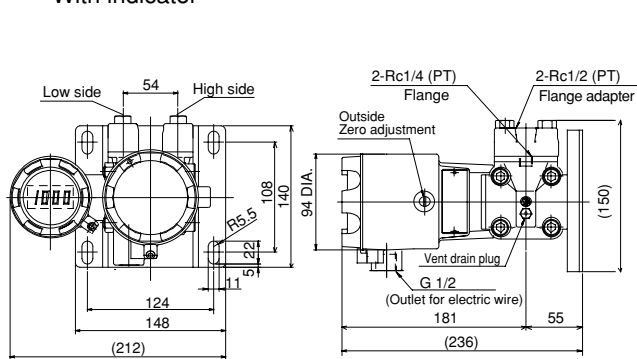

Surface mounting

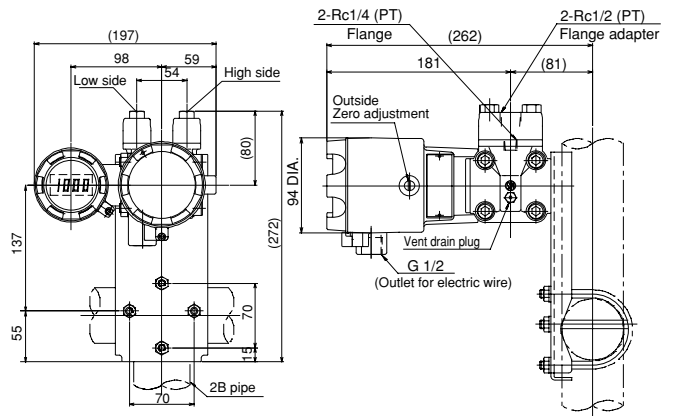

2B pipe mounting

## DIMENSION 3

### KD41 • 43 Explosion-protected construction pressure transmitter

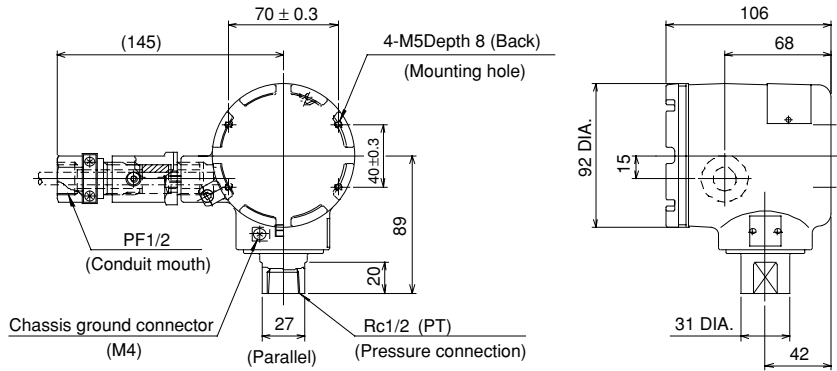

Stem mounting

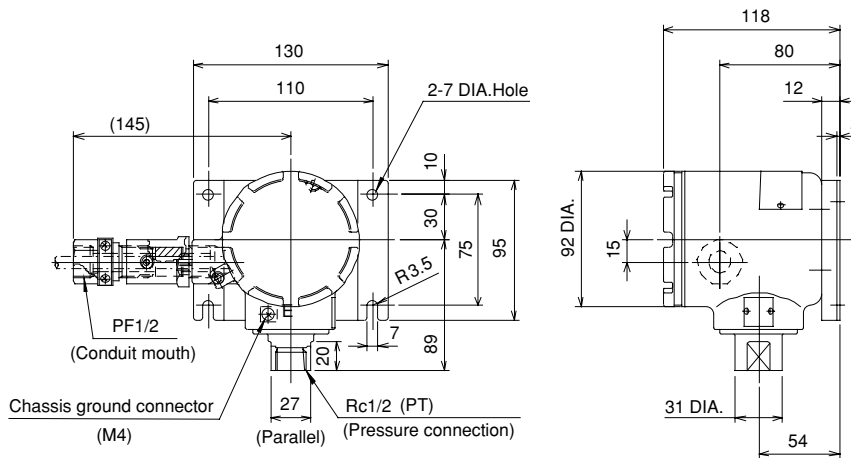

Surface mounting

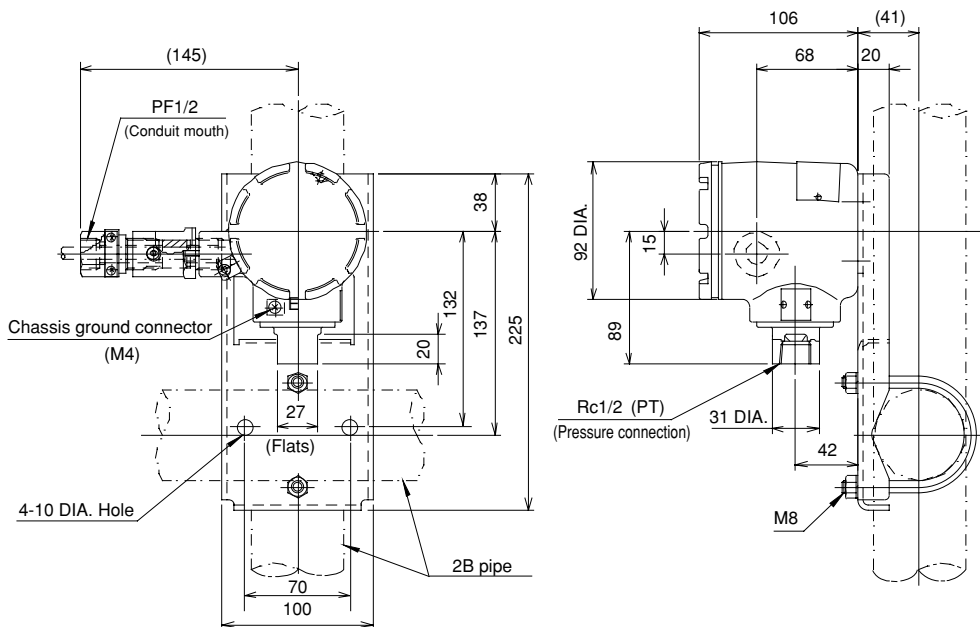

2B pipe mounting

# DIMENSION 4

## KD45 Explosion-protected construction differential pressure transmitter

Without indicator

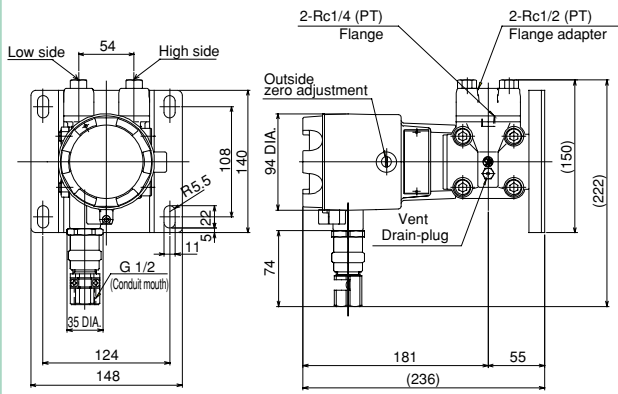

Surface mounting

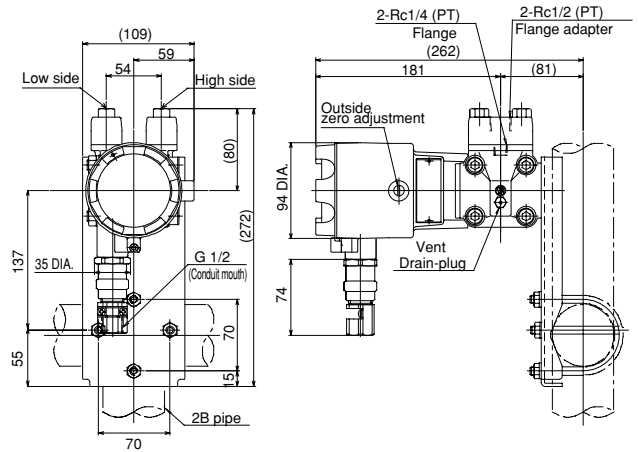

2B pipe mounting

With indicator

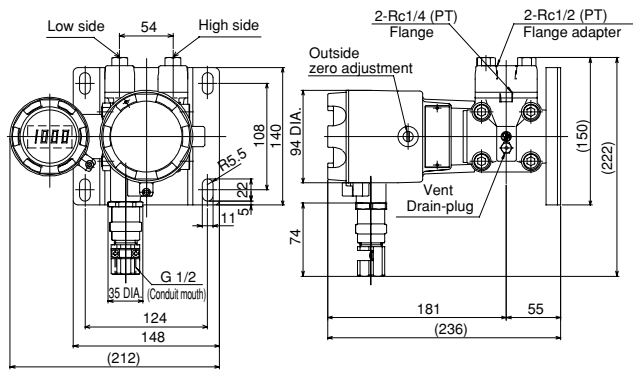

Surface mounting

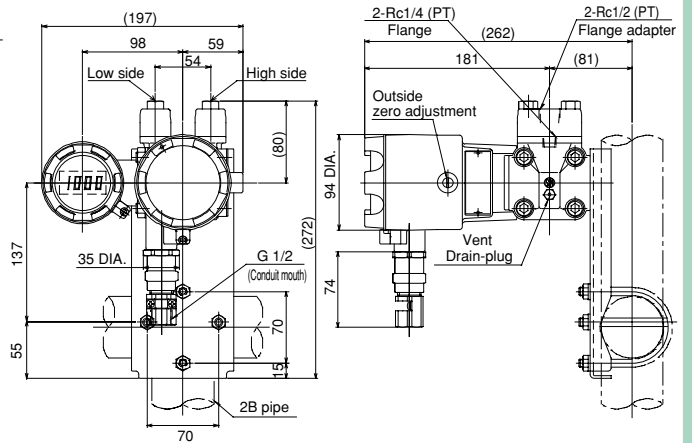

2B pipe mounting

## ZERO SUPPRESSION & ZERO ELEVATION

## Differential pressure transmitter (KH45 • KD45)

### Zero point shift:

Since the internal circuit is operated with +/- power source, it is available to shift to zero point in 5 steps by change-over switch. Zero suppression is to shift the zero point to plus side and zero elevation is to shift to minus side.

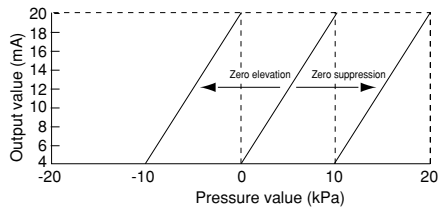

Zero point transition graph

At the measurement of Tank Level which is shown in the right figures, when the instrument is installed below the tank like figure B) & C), output signal of zero point changes. But by calibrated zero point by customer, same instruments can be used.

### A figure of liquid level measurement of a tank:

#### (A) Normal condition

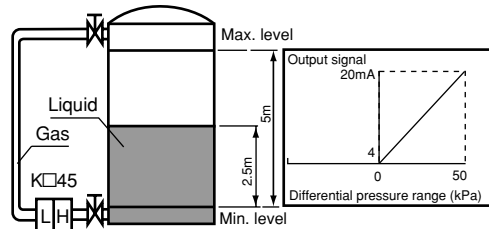

#### (B) Zero suppression

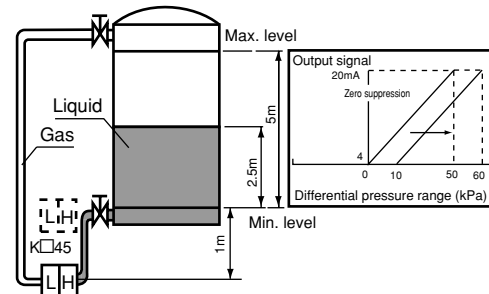

#### (C) Zero elevation

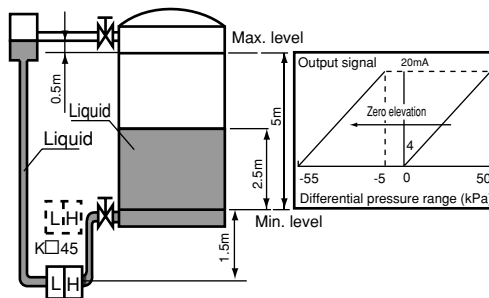

### Range ability:

Wide adjustment is available. Between minimum and maximum span in the figure shown below, customer can set the range freely.

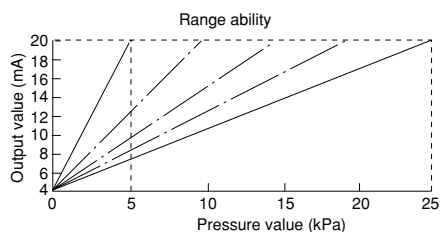

# Type No. constitution

Please specify Type No., each specification and range when ordering.

Note: For this Model, there is no applicable item for figures X, but please specify X when ordering.

Pressure	K	H	4	4	Pressure for general process (Medium low pressure)	Weight Approx. 1.8kg ~ 0.85kg ~
	K	H	4	3		
	K	D	4	4	Explosion-protected construction pressure (Medium low pressure)	
	K	D	4	3		
Differential pressure	K	H	4	5	Differential pressure for general process	Approx. 5kg ~
	K	D	4	5	Explosion-protected construction differential pressure	

KH:  
For general process  
KD:  
Explosion-proof

Pressure (Differential pressure) transmitter

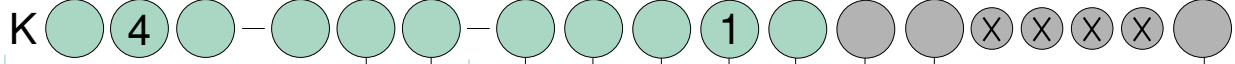

## 1 Mounting

Possible or not	KH41	KH43	KH45	KD41	KD43	KD45
1 Steam mounting	○	○	—	○	○	—
2 Surface mounting	○	○	○	○	○	○
3 2B pipe mounting	○	○	○	○	○	○
6 Surface mounting With digital display	—	—	○	—	—	○
7 2B pipe mounting With digital display	—	—	○	—	—	○

## 2 Connection

Possible or not	KH41	KH43	KH45	KD41	KD43	KD45
7 Rc1/4	○	○	○	—	—	○
9 Rc1/2	○	○	○	○	○	○

## 3 Wetted parts material

3	KH41: SCS14+316 st.st. KH45: Diaphragm 316L st.st., Flange SCS14 O-ring NBR, Gasket Teflon KD41: SCS14+316 st.st.+304 st.st. KD45: Diaphragm 316L st.st., Flange SCS14 O-ring NBR, Gasket Teflon
6	KH43: 316 st.st.+Co-Ni alloy KD43: SCS14+316 st.st.+Co-Ni alloy+304 st.st.

## 4 Pressure range

In case of KH41 • KD41

(When ordering, please specify pressure range & unit.)

1	0 ~ 5, 10, 20, 30, 40, 50kPa
2	0 ~ 0.1, 0.2MPa, -0.1 ~ 0MPa
3	-5 ~ +5, -10 ~ +10, -20 ~ +20kPa -30 ~ +30, -40 ~ +40, -50 ~ +50kPa
4	-0.1 ~ 0.1, 0.2MPa

## 4 Pressure range

In case of KH43 • KD43

(When ordering, please specify pressure range & unit.)

1	0 ~ 0.3, 0.5, 1, 2, 3.5, 5, 10, 20MPa 0 ~ 35, 50MPa K43 only
2	-0.1 ~ 0.3, 0.5, 1, 2MPa

## 4 Pressure range

In case of KH45 • KD45

(When ordering, please specify pressure range & unit.)

1	1.2 ~ 6kPa
2	5 ~ 25kPa
3	20 ~ 100kPa

## 10 Other additional spec.

0	Nil
1	Please specify your requirement Diaphragm seal type option (K□ 41 • 43 only) Manifold: FV43 • XX1 Flange S35C (K□ 45 only) Manifold: FV43 • XX3 Flange SUS (K□ 45 only)

## 9 Treatment

0	Nil
1	Use no oil
2	Use no water
3	Use no oil & water

## 8 Outlet for electric wire KH4 □

2	KH41 • 43: PF1/2 female KH45: G1/2
---	---------------------------------------

## 8 Outlet for electric wire KD4 □

0	Packing type cable gland
---	--------------------------

## 7 Output

1	4 ~ 20mA DC (2 wire system)
---	-----------------------------

## 6 Display (Power source)

0	Without display [12 ~ 32V DC (Standard24V DC)]
1	LCD digital display [17 ~ 32V DC (Standard24V DC)] K□ 45 only

## 5 Accuracy

3	±0.25%F.S. K□ 45 is not available.
4	±0.5%F.S.

## 15 Document

0	Nil
1	Please specify your requirement Drawing one sheet, Instruction manual, Inspection procedure, Mill sheet, Test report