



# Model KH62 Differential Pressure Transmitter

## OUTLINE

This differential pressure transmitter is a converter installed at measuring points in jog site, sensing a differential pressure, a liquid surface level and a liquid flow, converting them into direct current signals and transmitting them. The sensing method is that a force corresponding to inputted differential pressure is converted into electrical signals by an evaporation type semiconductor strain gauge. As high reliability is provided, it can be appropriately used in ships, because the ship class standard including NK Approval and NV Approval\*<sup>1</sup> have been awarded.

## FEATURES

- This differential pressure transmitter can endure high pressure because of charged liquid.
- The front side is a screw type cover and is easily detached. Adjustment is easily performed by the electric zero-span method.
- The construction is of small, light weight and drip-proof type.
- A built-in terminal is provided. As a test terminal is provided, a test can be performed without opening an output circuit. Additionally, an inverse polarity protection circuit is also equipped.

## SPECIFICATION 1

### Fluid :

Liquid, gas or steam

### Operating condition:

Under the normal condition, where there is no inflammable gas or liquid which cause the ignition or explosion.

### Mounting:

Surface mounting



2B pipe mounting

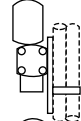

Surface mounting  
(With 3-way manifold valve)

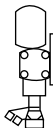

2B pipe mounting  
(With 3-way manifold valve)

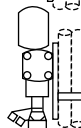

\* Intrinsically safe explosion-protected construction (3aG4) is available (Model: KJ62)

\* With indicator type or diaphragm seal type is also available.

\* 1 If the goods approved by NV is required, please inform it.

### Connection:

R c1/4, R c1/2

### Wetted parts material :

Flange	SCS14, SS400 or 316st.st. (Depending on range)
Diaphragm, Body	316st.st.
Gasket	Teflon
O-ring	NBR

### Differential pressure range:

0 ~ 0.3kPa → 0 ~ 2MPa

### Operating pressure range:

0 ~ 1MPa, 0 ~ 5MPa, 0 ~ 10MPa  
(Depending on differential pressure range)

### Power source:

24V DC ± 10%

### Output:

4 ~ 20mA DC

### Load resistance:

500Ω max.

### Transmission system:

2 wire system

### Operating temperature:

-10 ~ 60°C (But fluid should not be frozen)

### Storage temperature:

-20 ~ 70°C

### Accuracy:

± 0.5%F.S. or ± 1.0%F.S.  
(Depending on differential pressure range)

### Temperature coefficient:

± 0.05%F.S./°C (Zero, but at maximum span)  
± 0.05%F.S./°C (Span)

### Influence of static pressure:

Zero point output change generated by the impression of a static pressure on the high and low pressure side simultaneously.  
Within ± 0.5% (At max. span of each range)

## SPECIFICATION 2

### Influence of one side pressure:

Zero point output change generated by the alternate impression of a static pressure on the high and low pressure sides (Within  $\pm 1.5\%$ )

### Influence of mounting style:

Diaphragm: It does influence in a turn in a plane.  
Within 0.2kPa/22.5

### Filled liquid:

Silicone oil

### Outlet for electric wire:

Gland JIS 20b

### Case material - finishing:

Aluminium alloy die casting (ADC12) · Gray

### Construction:

Splash-proof (IP54)

### Elevation and suppression:

Adjustable nearly half of max span of elevation and suppression at zero point.

### Standard accessories:

Flange adapter Vent/drain valve

### Weight:

Approx. 8kg (1.2kPa or below Approx.10kg)

Accuracy · operating pressure range · Flange material:

Differential pressure range	Accuracy	Operating pressure range	Flange material
0-0.3 ~ 0-1.2kPa	$\pm 1.0\%$ F.S.	0 ~ 1MPa One side proof pressure is same as operating pressure range	SCS14
0-1.21 ~ 0-4.5kPa 0-4.51 ~ 0-9.0kPa 0-9.01 ~ 0-19.0kPa 0-19.01 ~ 0-40.0kPa	$\pm 0.5\%$ F.S.	0 ~ 5MPa, 0 ~ 10MPa One side proof pressure is same as operating pressure range	Operating pressure 5MPa or below SCS14 Operating pressure 10MPa or below SS400 or 316 st.st.
0-40.01 ~ 0-80.0kPa 0-0.1 ~ 0-0.4MPa 0-0.5 ~ 0-2.0MPa	$\pm 1.0\%$ F.S.	0 ~ 5MPa, 0 ~ 10MPa One side proof pressure is 300% of each differential pressure range	

## WIRING

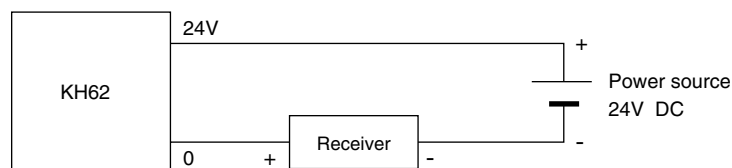

## SPECIFICATION 3

### Suppression and elevation:

- (A) The zero point (4mA point) of a suppression type transmitter can be moved to the positive side of an actual differential pressure. The suppression type is used for an open tank, as shown, where a positive load is applied on side H of the transmitter even when the tank is empty.

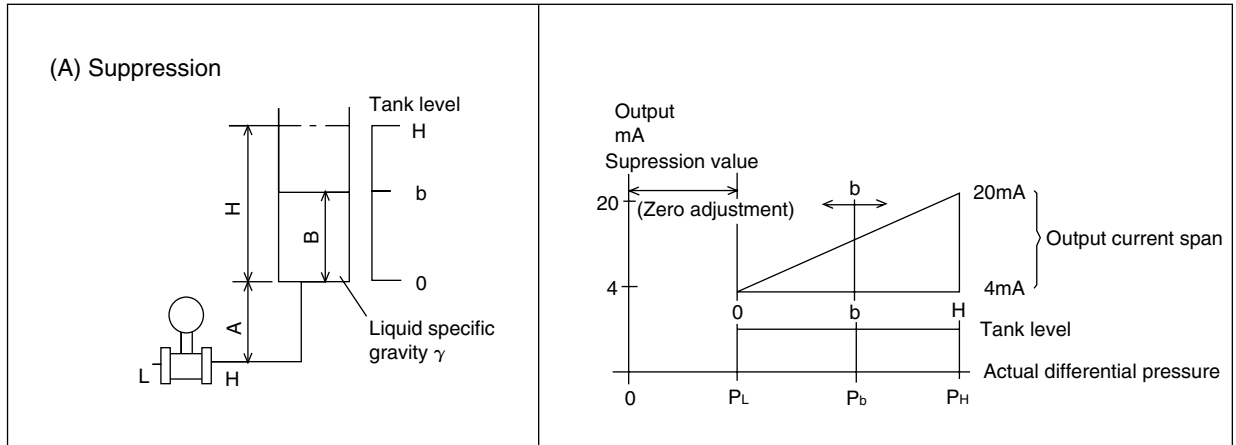

- (B) In case of closed tank as shown, even tank level is at  $H$  point, if a negative load may be applied on H side of the transmitter, the zero point (4mA point) can be moved to the negative side of an actual differential pressure.

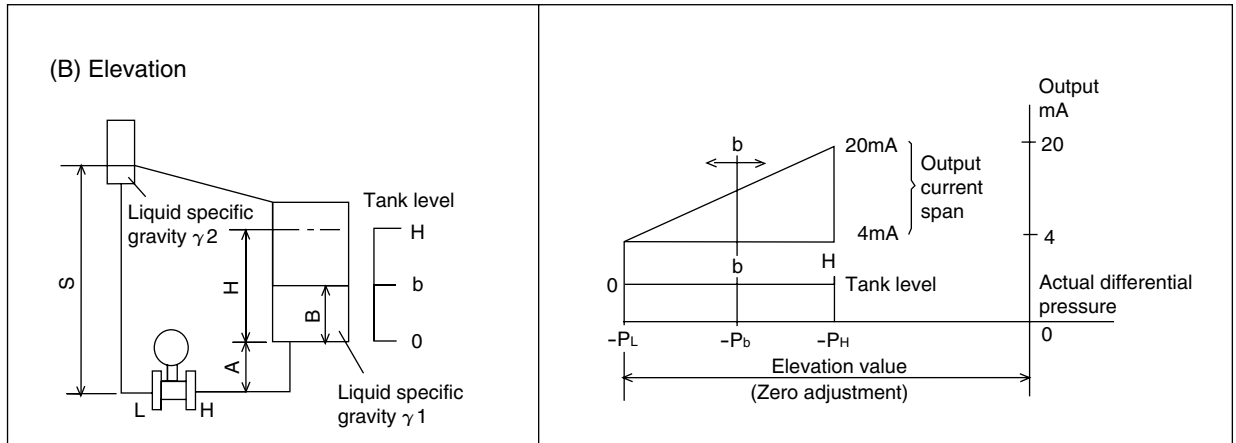

# DIMENSION

The measurements in the diaphragms are when the flange material is SCS14.  
 (Please contact NKS when the material is SS400 or 316st.st.)

\* Mark is applied to range 0 – 0.3 ~ 0 – 1.2kPa

**2B pipe mounting**

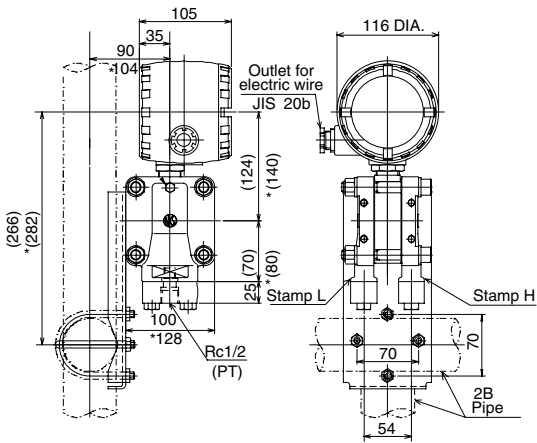

**Surface mounting**

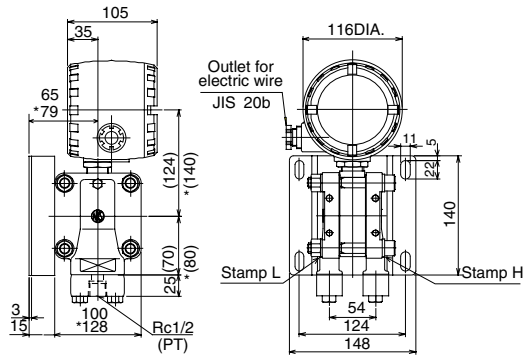

**2B pipe mounting with 3-way manifold valve**

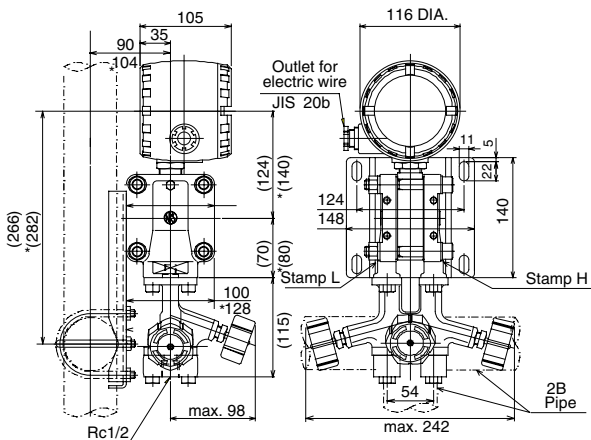

**Surface mounting 3-way manifold valve**

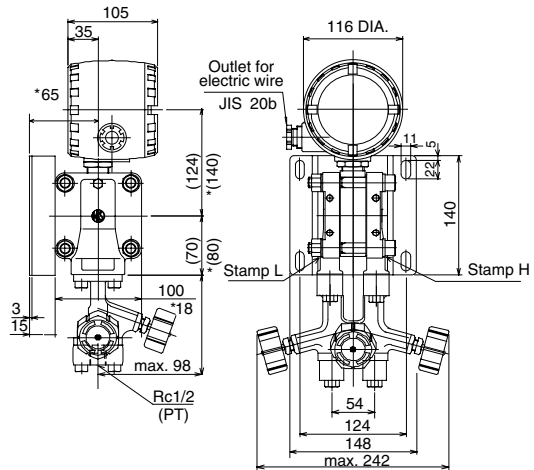

# Type No. constitution

Please specify Type No., each specification and range when ordering.

Note: For this Model, there is no applicable item for the figures X, but please specify X when ordering.

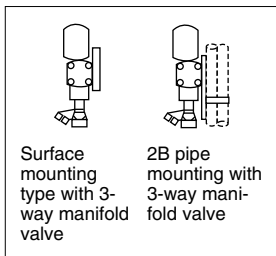

## 123 Mounting

T01	Surface mounting with 3-way manifold valve (S35C)
T02	Surface mounting with 3-way manifold valve (316st.st.)
T06	NK class authorization product Surface mounting with 3-way manifold valve (S35C)
T07	NK class authorization product Surface mounting with 3-way manifold valve (316st.st.)
T31	2B pipe mounting with 3-way manifold valve (S35C)
T32	2B pipe mounting with 3-way manifold valve (316st.st.)
T36	Type approved by NK 2B pipe mounting with 3-way manifold valve (S35C)
T37	Type approved by NK 2B pipe mounting with 3-way manifold valve (316st.st.)

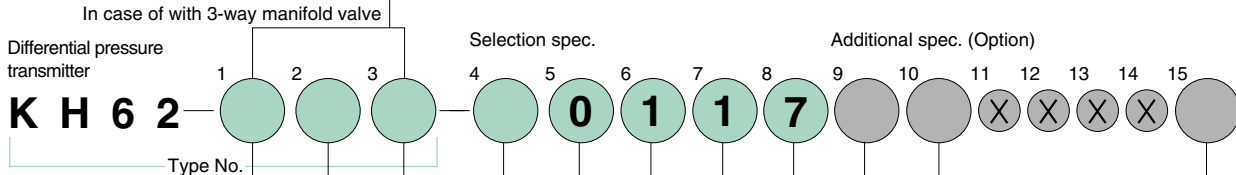

Basic specification of KJ62 of Intrinsic Safety Construction is same as KH62. Zenner barrier is attached.

## 1 Mounting

2	Surface mounting type
3	2B pipe mounting
5	Type approved by NK Surface mounting type
6	Type approved by NK 2B pipe mounting

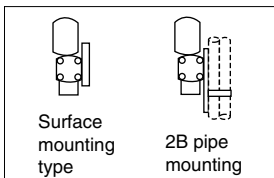

## 2 Connection

7	Rc1/4
9	Rc1/2

## 3 Flange material

1	SCS14	Operating pressure range: 5MPa or less
2	SS400	Operating pressure range: 10MPa or less
3	316st.st.	Operating pressure range: 10MPa or less

## 4 Differential pressure range

(When ordering, please specify pressure range & unit.)

1	0-0.3 ~ 0-1.2kPa	±1.0%F.S.
2	0-1.21 ~ 0-4.5kPa	±0.5%F.S.
3	0-4.51 ~ 0-9.0kPa	±0.5%F.S.
4	0-9.01 ~ 0-19.0kPa	±0.5%F.S.
5	0-19.01 ~ 0-40.0kPa	±0.5%F.S.
6	0-40.01 ~ 0-80.0kPa	±1.0%F.S.
7	0-0.1 ~ 0-0.4MPa	±1.0%F.S.
8	0-0.5 ~ 0-2.0MPa	±1.0%F.S.

## Selection spec.

## Additional spec. (Option)

10 Other additional spec  
(No need, if Type No. is with 3-way manifold valve.)

0	Nil
1	Please specify your requirement Manifold: FV43-XX1 Flange S35C Manifold: FV43-XX3 Flange st.st.

## 9 Treatment

0	Nil
1	Use no oil
2	Use no water
3	Use no oil & water

## 8 Outlet for electric wire

7	JIS 20b
---	---------

## 7 Output

1	4 ~ 20mA DC (2 wire system)
---	-----------------------------

## 6 Power source

1	24V DC ±10%
---	-------------

## 5 Accuracy

0	Standard ±0.5 % F.S. or ±1.0 % F.S. (Depending on differential pressure range)
---	--------------------------------------------------------------------------------------

## 15 Document

0	Nil
1	Please specify your requirement Drawing one sheet, Instruction manual, Inspection procedure, Mill sheet, Test report