



Temperature Switches

OUTLINE

This temperature switch consists of a temperature element and a switch.

The pressure type temperature element, in which liquid is charged and its expansion and contraction are applied, is used.

This temperature switch is classified into the non-mercury organic liquid filled type and the mercury filled type.

Additionally, a microswitch for industrial application is used, and this catalog is formed by classifying this temperature switch into the drip-proof type and the explosion-protected type according to the construction of the case.

* When selecting a thermometer, select a thermometer which is normally applied to a temperature range of 30% to 60% of full span. Check to confirm that the material of the wetted parts is appropriate to measuring gas or liquid.

SPECIFICATION

Manufacturing temperature range:

Liquid filled type -70°C ~ 300°C

Mercury filled type -30°C ~ 600°C

Use switch:

Industrial switch

Construction:

Drip-proof type

Explosion-protected type (d2G4)

Mounting:

Remote type, surface mounting

(2B pipe mounting is available for explosion-proof type)

Bulb • Connection material:

304st.st.

Lead tube part material:

Capillary 304st.st. or 316st.st.

Armored tube 430st.st. or 430st.st.+PVC

Connection:

R1/2 (PT) , R3/4 (PT) , 1/2NPT, G1/2B (PF) ,
G3/4B (PF)

JIS10K20ARF, JIS10K25ARF,

ANSI1B150RF, ANSI1B300RF

* For other connections, please contact us.

Number of contact:

Liquid filled type One contact, two contact

Mercury filled type One contact

Accuracy:

Repeatability Within 2%F. S.

SELECTION GUIDE OF TEMPERATURE SWITCH 1

1. Features of micro switch

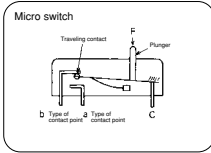

Micro switch is able to take electricity rating greatly, and is available for various control other than dispatch of warning with safety from vibration.

Electric characteristics:

Electric rating		Withstand voltage	Instlation resistance
Resistance load	Inductive load		
125VAC 15A	(Power factor more than 0.4 or Time-contact 7ms or less)	1500VAC 1 minute	500VDC megger 100MΩ over
250VAC 15A			
30VDC 2A			
125VDC 0.5A			
	125VDC 0.05A		

2. Explosion protected temperature switches

The electric appliance, which is used at hazardous areas where inflammable gas or liquid causing ignition explosion exists, is imposed use of the the explosion protected products which passed national official approval.

Thermometers with electric contact used at each place of the factory, indoor storage, outdoor tank storage, indoor tank storage, general handling place, passage handling place of dangerous materials is available for pressure-proof and explosion-proof type.

3. Compensation system by installation place

When the ambient temprature around temperature gauge changes, the filled liquid in the indicator and capillary tube also changes to expand or shrink and this causes the indication error. To compensate this error, following compensations are provided.

(1)Bimetal compensation (TS30)

- When the temperature around indicator and lead parts changes at a same time.

(2)Lead compensation (TS50, TD50)

- When the ambient temperature around indicator and lead parts changes independently.
 - 1) When the temperature change around indicator is small and big for lead parts or it's opposite case.
 - 2) When the lead parts is under various ambient temperature condition.
 - 3) When a part of lead parts is heated.

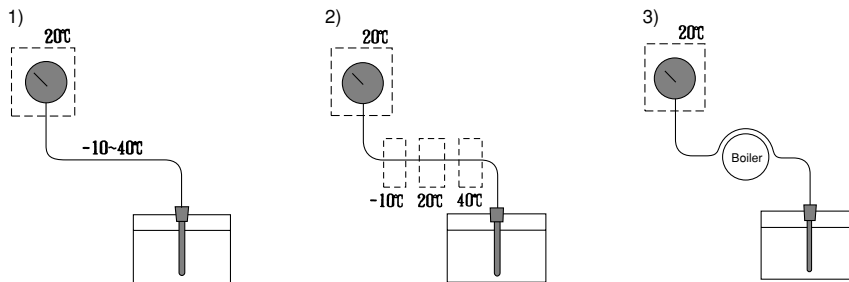

4. Temperature range (Scale range)

- Scale range should be selected to use normally between 30 to 60% of full span.
- When the temperature exceeds the temperature range, it may cause to break the temperature gauge. For example, if there will be a case that the gauges pass the right on the equator or cold district during transportation, or store them at cold district, it needs careful attention.

Normal using range

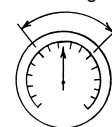

SELECTION GUIDE OF TEMPERATURE SWITCH2

5. Bulb type

Union type

- Standard spec.

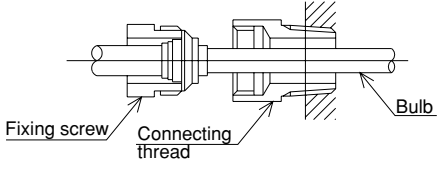
	<p>By tightening the fixing screw, it fixed to the connecting thread so that position of bulb dose not change.</p>	<p>Maximum allowable working pressure of union type is Less than 200°C→2MPa Over200°C→1MPa (If the pressure is higher than above, thermowell should be provided.)</p>
---	--	--

Slide type

- At the time when it needs to adjust the bulb position by the changing the position of fluid to be measured in a tank or other vessel.
- At the time when it needs to insert the bulb up to the bottem of thermowell.

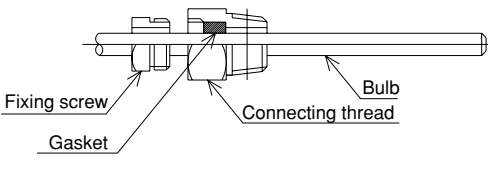
	<p>By tightening the gasket with fixing screw, bulb can be fixed at any position.</p>	<p>Maximum allowable working pressure of slide type is 0. 3MPa (If the pressure is higher than above, thermowell should be provided.)</p>
---	---	--

Plain type

- In case the bulb to be casted into the fluid.

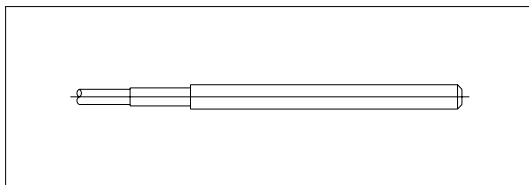

6. Bulb minimum insertion length

- According to type, temperature range and bulb diameter, minium insertion length is decided.
- When placing order or decide the specifications, select a suitable lenth which is longer than the minimum insertion length to keep the performance.

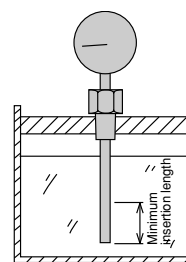

A good exaple

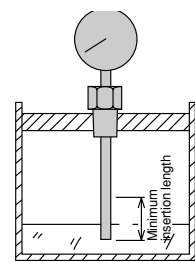

A bad example

7. Thermowell

In the case of following conditions, thermowell should be provided to protect bulb.

- (1) In case of corrosion fluid, thermowell with suitable material is necessary.
- (2) In case of high pressure, necessary to use thermowell suitable for operating pressure.
- (3) In case of fluid with flow, necessary to use thermowell suitable for flow and viscosity.
- (4) In case of fluid leaking out when taking off the thermomerer, necssary to use thermowell.
- (5) In case of filled liquid in thermometer is leak out from bulb and it is harmful, necessary to use thermowell.

(1)

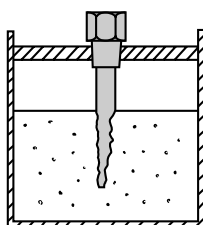

Corrosion

(2)

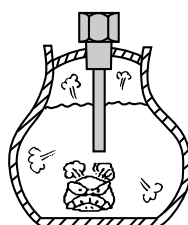

High pressure

(3)

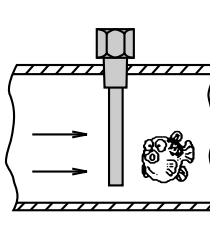

Flow

(4)

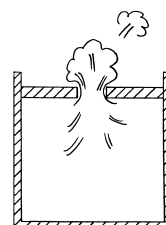

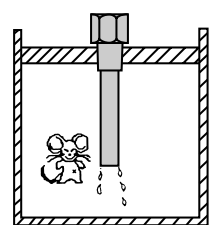

Taking off thermomer

(5)



Leakage of filled liquid

TEMPERATURE SWITCHES SPECIFICATION

	Mounting	Sensing method	Manufacturing range	Type of contact	Compensation	Max.lead length	Model
Drip-proof type		Liquid filled type	-70°C ~ 50°C ↓ 0°C ~ 300°C	One contact or two contact	Lead compensation	10m	TS50
		Mercury filled type	-30°C ~ 50°C ↓ 0°C ~ 600°C	One contact	Bimetal compensation	10m	TS30
Explosion protected type		Liquid filled type	-70°C ~ 50°C ↓ 0°C ~ 300°C	One contact or two contact	Lead compensation	20m	TD50

CONNECTION • BULB SPECIFICATION

1. Without thermowell

		Connection		d DIA.	Note
		Screw type	Flange type		
Union type	<p>Max. operating pressure: 2MPa (20kg f/cm²) for less than 200g 1MPa (10kg f/cm²) for 200g or over</p>		8 DIA.	• Slide type is not available.	
			10 DIA.	_____	
Slide type	<p>Max. operating pressure 0.3MPa (3kg f/cm²)</p>		12 DIA.	_____	
			13 DIA.	_____	
			16 DIA.	• T=1/2 is not available. • Slide type is not available.	

2. With thermowell

		Connection		d DIA.	d DIA.	Note
		Screw type	Flange type			
Standard type	Union type			12 DIA.	8 DIA.	_____
	Slide type			15 DIA.	10 DIA.	_____
Double socket type	Union type			19 DIA.	13 DIA.	• T=1/2 is not available.
	Slide type			13 DIA.	13 DIA.	• T=1/2 is not available. • Welding type well not available.
				Taper 19 DIA. 23	13 DIA.	• T=1/2 is not available. • Welding type well not available.

	Screw rating	Flange rating
Standard connection	R1/2 (PT) , 1/2NPT G1/2B (PF) R3/4 (PT) , G3/4B (PF) (Fixing screw only=W22 thread 14)	JIS10K20ARF JIS10K25ARF ANSI1B150RF ANSI1B300RF

Note
Other connections except shown left are available. Contact NKS for details.

3. Plain type

	Bulb
Plain type	<p>d DIA.=8 DIA., 10 DIA., 12 DIA., 13 DIA., 16 DIA.</p>

TYPE OF CONTACT AND WIRING SYSTEM

TS50 (Liquid filled type)

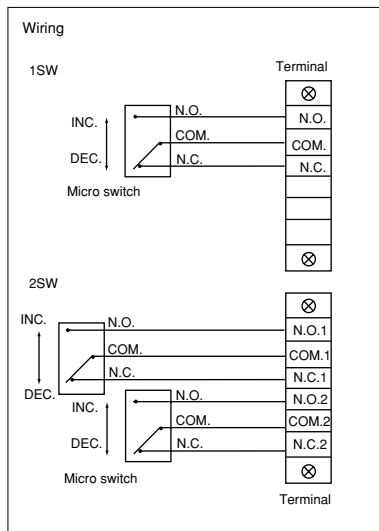

TD50 (Liquid filled type)

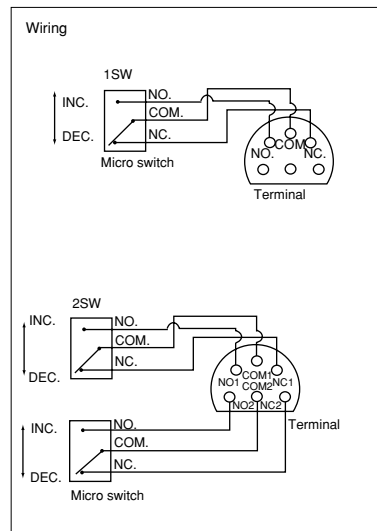

N. O. (Normally open)	Terminal of micro switch circuit is normally open at minimum temperature
N. C. (Normally closed)	Terminal of micro switch circuit is normally closed at minimum temperature
Upper limit type with one contact H (Reverse lower limit one contact LR)	System by which the contacts close (open) when the temperature increases (decreases) to the set point. (Reverse lower limit wiring is the same as upper limit.)
Lower limit type with one contact L (Reverse upper limit type with one contact HR)	System by which the contacts close (open) when the temperature decreases (increases) to the set point. (Reverse upper limit wiring is the same as lower limit.)
Upper and lower limits two contact HL (Reverse lower and upper limits type with two contact HR, LR)	Combination of upper limit system and lower limit system. There are types whose contacts operate independently (Dual setting, dual circuits) and types whose contacts operate simultaneously (Single setting, dual circuits)
Upper limit type with two contact 2H (Reverse lower limit type with two contact 2LR)	Combination of two upper limit systems. There are types whose contacts operate independently and types (Dual setting, dual circuits) whose contacts operate simultaneously (Single setting, dual circuits)
Lower limit type with two contact 2L (Reverse upper limit type with two contact 2HR)	Combination of two upper limit systems. There are types whose contacts operate independently and types (Dual setting, dual circuits) whose contacts operate simultaneously (Single setting, dual circuits)

TS30 (Mercury filled type)

1. Upper limit type with one contact • H (Connecting ③ - ④)

When temperature increases to the setting point or higher, the contact activates, turning on the circuit. The off point at the time of temperature decrease will be deviated according to the dead-band of the microswitch

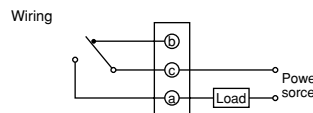
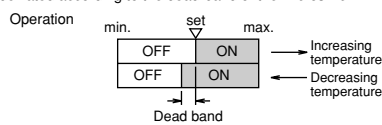

This model can be used as a lower limited type (Connecting ⑤ - ⑥). However, the setting requires the compensation corresponds to the dead-band.

2. Lower limit type with one contact • L (Connecting ⑤ - ⑥)

When temperature decreases to the setting point or lower, the contact activates, turning on the circuit. The off point at the time of temperature increase will be deviated according to the dead-band of the microswitch

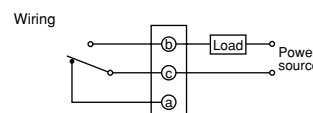
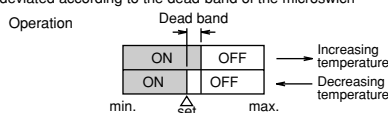

This model can be used as an upper limited type (Connecting ③ - ④). However, the setting requires the compensation corresponds to the dead-band.

EXPLOSION-PROOF

Explosion-protected construction

Explosion-protected construction is a totally enclosed construction such that even if the explosive gas explodes inside the container, the container withstands the force of the explosion and there is no danger of ignition of external explosive gases.

Application range: d2G4

- 1) Explosion-protected construction: d
- 2) Explosion class : 2
- 3) Ignitability : G4
- 4) Hazardous areas : Zone 1 or zone 2
- 5) Objective industries : Petrochemical, chemical fiber, synthetic resin, ethylene, methanol, dielectric products manufacturing, liquefied gas, electric furnace, pharmaceuticals, paints, ammonium sulfate, soda, other measurement medium or industries in which there is the danger of ignition and explosion.

Classification of hazardous areas:

Hazardous area	Contents
Zone 0	A place where hazardous atmosphere is continuously present or present for a long period under ordinary circumstances.
Zone 1	A place where hazardous atmosphere is likely to occur under ordinary circumstances.
Zone 2	A place where hazardous atmosphere is likely to occur under abnormal circumstances.

Classification of explosion:

Explosion class	Minimum gap with a 25mm length of patch which permits the flame propagation.
1	Over 0.6mm
2	0.4mm to 0.6mm
3	Up to 0.4mm

Explosion test equipment

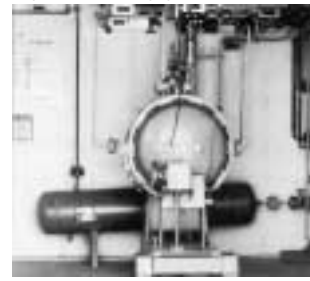

Classification of ignition groups:

Ignition class	Ignition point	Limits of temperature rise (deg)
G1	Over 450°C	320
G2	300°C to 450°C	200
G3	200°C to 300°C	200
G4	135°C to 200°C	200
G5	100°C to 135°C	200
G6	85°C to 100°C	200

The standard ambient temperature range limit of the electrical instrument in the normal using shall be 40°C

Example of classification of typical explosive gases:

Ignition class / Explosion class	G1	G2	G3	G4	G5	G6
1	Acetone	Ethanol	Gasoline	Acetaldehyde		
	Ammonia	Amylacetate-iso	Hexane	Ethyl ether		
	Carbon monoxide	1-Butanol				
	Ethane	Butane				
	Acetic acid	Butyric anhydride				
	Ethyl acetate					
	Toluene					
	Propane					
	Benzene					
	Methanol					
	Methane					
2	Carbon gas	Ethylene Ethyleneoxide				
	Water gas Hydrogen	Acetylene			Carbon dioxide	

LIQUID FILLED TYPE • TEMPERATURE SWITCHES1

TS50 Drip-proof type



■ Dimension

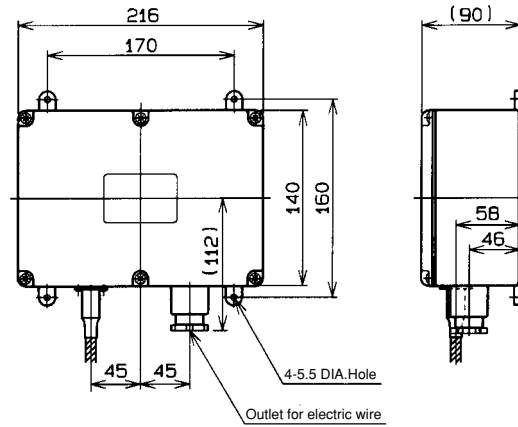

Weight: Approx. 2kg (Indicator)

TD50 Explosion protected type (d2G4)



■ Dimension

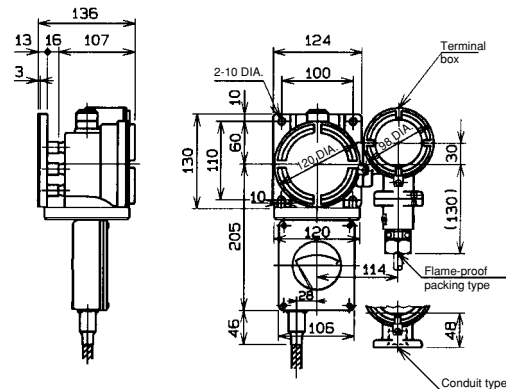

Weight: Approx. 5kg (Indicator)

Registered model for labor ministry inspection CD50 • 2
Approval number for labor ministry inspection No.25230

■ Specification

Manufacturing range	-70 ~ 300°C	
Case	TS50: Drip-proof • IP33 (IP65 is available), TD50: Explosion protected type • IP54 Material: TS50 • Aluminum alloy casting (AC7A), TD50 • Aluminum alloy die casting (ADC12), Finishing: Gray	
Weeted parts material	Bulb: 304st.st., Connection • Flange: 304st.st.	
Accuracy (Repeatability)	Within 2%F. S.	
Indication accuracy	Within ±1 dial at 20°C (TD50 only)	
Dead band	Within 3%F. S.	
Ambient temperature erro	Within ±2%F. S. /15deg	
Number of contact	One contact • Two contact	
Setting system	Internal adjustment	
Lead length	Standard 3m, Max. TS50: 10m, TD50: 20m	
Compensation	Lead compensation	
Connection	R1/2 (PT), R3/4 (PT), 1/2NPT, G1/2B (PF), G3/4B (PF) 1/2is not available with 16 Dia. bulb and 19 Dia. 23 Dia thermowell	
Flange	JIS10K20ARF, JIS10K25ARF, ANSI1B150RF, ANSI1B300RF	
Connection	Without thermowell	Union type, Slide type
	With thermowell	Double socket union type: R1/2, 1/2NPT (Connection) Double socket slide type: R1/2, 1/2NPT (Connection)

* Other connections are available. Contact NKS for details.

LIQUID FILLED TYPE • TEMPERATURE SWITCHES2

■ Range • Bulb DIA. • Bulb length

() with thermowell

Range °C	Standard Bulb DIA. × length		Bulb length (L) mm					Max.
			Minimum insertion length					
			d=8 DIA. (d=12 DIA.)	d=10 DIA. (d=15 DIA.)	d=12 DIA.	d=13 DIA. (d=19 DIA.)	d=16 DIA. (d=23 DIA.)	
-70 ~ 50	10 (15)	150 (200)	160 (185)	130 (155)	100	90 (115)	75 (100)	500
-70 ~ 100	150 (150)	150 (150)	125 (150)	105 (130)	85	75 (100)	65 (90)	
-50 ~ 50	150 (200)	150 (200)	180 (205)	145 (170)	110	100 (125)	80 (105)	
-30 ~ 50	200 (200)	200 (200)	215 (240)	170 (195)	130	115 (140)	95 (120)	
-20 ~ 100	150 (200)	150 (200)	160 (185)	130 (155)	100	90 (115)	75 (100)	
-10 ~ 100	150 (200)	150 (200)	170 (195)	135 (160)	105	95 (120)	80 (105)	
-10 ~ 50	300 (300)	300 (300)	265 (290)	210 (235)	155	135 (160)	105 (130)	
0 ~ 50	300 (300)	300 (300)	355 (380)	270 (295)	195	170 (195)	135 (160)	
~ 60	300 (300)	300 (300)	315 (340)	245 (270)	180	155 (180)	120 (145)	
~ 80	200 (300)	200 (300)	245 (270)	195 (220)	145	125 (150)	100 (125)	
~ 100	200 (200)	200 (200)	205 (230)	165 (190)	125	110 (135)	90 (115)	
~ 120	150 (200)	150 (200)	180 (205)	145 (170)	110	100 (125)	80 (105)	
~ 150	150 (150)	150 (150)	155 (180)	125 (150)	100	90 (115)	75 (100)	
~ 200	100 (150)	100 (150)	110 (135)	95 (120)	75	70 (95)	60 (85)	
~ 250	100 (150)	100 (150)	100 (125)	85 (110)	70	65 (90)	60 (85)	
~ 300	100 (150)	100 (150)	90 (115)	80 (105)	65	60 (85)	55 (80)	

- Note • Above length is the minimum necessary length of bulb to be inserted into the fluid to be measured.
 • Bulb length should be over the above length and specify 5mm steps.
 • In case of plain type of bulb, minimum length to be added 40mm to the above length.

■ TD50 • Graduations

Range °C	Scale division and number entry position	Range °C	Scale division and number entry position
0 ~ 50		-10 ~ 50	
0 ~ 60		-30 ~ 50	
0 ~ 80		-50 ~ 50	
0 ~ 100		-10 ~ 100	
0 ~ 120		-20 ~ 100	
0 ~ 150		-70 ~ 50	
0 ~ 300		-70 ~ 100	
0 ~ 200			
0 ~ 250			

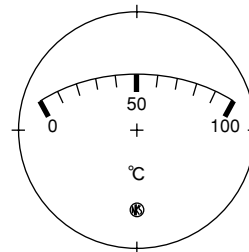

Ground: White

Entry: Black color, red for graduation line and figure of minus parts.

■ TD50 • Methods of leading external conductors and cable in to a terminal box

<1>Conduit type	<2>Flame-proof packing type	
<p>Conduit tube connection PF 3/4</p>	10.5	9.4
		9.9
	12	10.1
		10.5
		11.0
	14	11.5
		11.9
		12.0
		12.5
	15.5	12.6
		13.1
		13.5
		13.6
		14.5
	16.5	15.6
		<p>Terminal box Washer Ring packing M6 set screw Cable gland Cable clamp Cable protection tube connection Cable outside diameter</p>

MERCURY FILLED TYPE • TEMPERATURE SWITCH

TS30Drip-proof type



Dimension

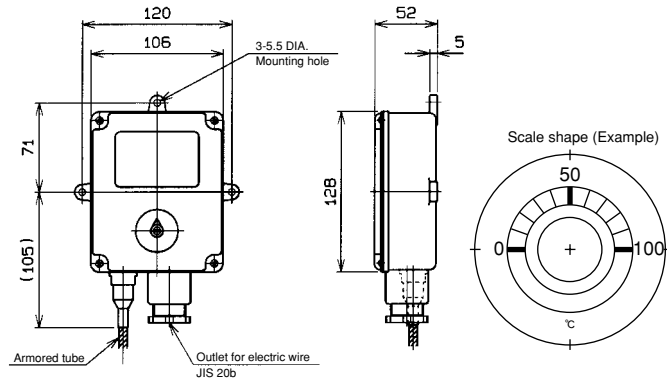

Specification

Manufacturing range	-30 ~ 600°C		
Case	Drip-proof type: IP43, Material: Aluminum alloy die casting (ADC12), Finishing: Black		
Accuracy (Repeatability)	Within 2%F. S.		
Accuracy (Setting)	Within ±4%F. S.		
Dead band	Within 6%F. S.		
Ambient temperature error	Within ±2%F. S. /15deg		
Number of contact	One contact		
Setting system	External adjustment		
Lead length	Standard 3m, Max.10m		
Compensation	Bimetal compensation		
Connection	R1/2 (PT), R3/4 (PT), 1/2NPT, G1/2B (PF), G3/4B (PF) 1/2 is not available with 16 Dia. bulb and 19 Dia. 23 Dia thermowell		
Flange	JIS10K20ARF, JIS10K25ARF, ANSI1B150RF, ANSI1B300RF		
Connection	Without thermowell	Union type, Slide type	
	With thermowell	Double socket union type: R1/2, 1/2NPT (Connection)	Slide type is not available with 16 Dia. bulb.
		Double socket slide type: R1/2, 1/2NPT (Connection)	

Range • Bulb DIA. • Bulb length

Value in parenthesis is the case with thermowell

Range °C	Standard Bulb DIA. × length d (d1) × L (L)	Bulb length (L) mm					Max.
		Minimum insertion length					
		d=8 DIA. (d=12DIA.)	d=10DIA. (d=15DIA.)	d=12DIA.	d=13DIA. (d=19DIA.)	d=16DIA. (d=23DIA.)	
-30 ~ 50	10 (15) × 250 (250)	270 (290)	205 (225)	145	125 (145)	95 (115)	d=8DIA., 16DIA. 1000
-30 ~ 120	× 150 (200)	155 (175)	120 (140)	90	75 (95)	60 (80)	
-20 ~ 100	× 200 (200)	190 (210)	145 (165)	105	90 (110)	70 (90)	
-10 ~ 50	× 300 (300)	355 (375)	265 (285)	185	160 (180)	120 (140)	
0 ~ 50	× 350 (350)	420 (440)	315 (335)	220	185 (205)	140 (160)	
~ 60	× 300 (350)	355 (375)	265 (285)	185	160 (180)	120 (140)	
~ 80	× 250 (250)	270 (290)	205 (225)	145	125 (145)	95 (115)	
~ 100	× 200 (250)	220 (240)	170 (190)	120	105 (125)	80 (100)	
~ 120	× 200 (200)	190 (210)	145 (165)	105	90 (110)	70 (90)	
~ 150	× 150 (200)	155 (175)	120 (140)	90	75 (95)	60 (80)	
~ 200	× 150 (150)	125 (145)	95 (115)	70	65 (85)	50 (70)	
~ 250	× 100 (150)	105 (125)	80 (100)	65	55 (75)	45 (65)	
~ 300	× 100 (150)	90 (110)	75 (95)	55	50 (70)	40 (60)	
~ 400	× 100 (100)	75 (95)	60 (80)	50	45 (65)	40 (60)	
~ 500	× 100 (100)	65 (85)	55 (75)	45	40 (60)	40 (60)	
~ 600	× 100 (100)	55 (75)	50 (70)	40	40 (60)	60 (80)	

Note • Above length is the minimum necessary length of bulb to be inserted into the fluid to be measured.
 • Bulb length should be over the above length and specify 5mm steps.
 • In case of plain type of bulb, minimum length to be added 40mm to the above length.

Type No. constitution

Please specify Type No., each specification and range when ordering.

Note: For this Model, there is no applicable item for the figures X, but please specify X when ordering.

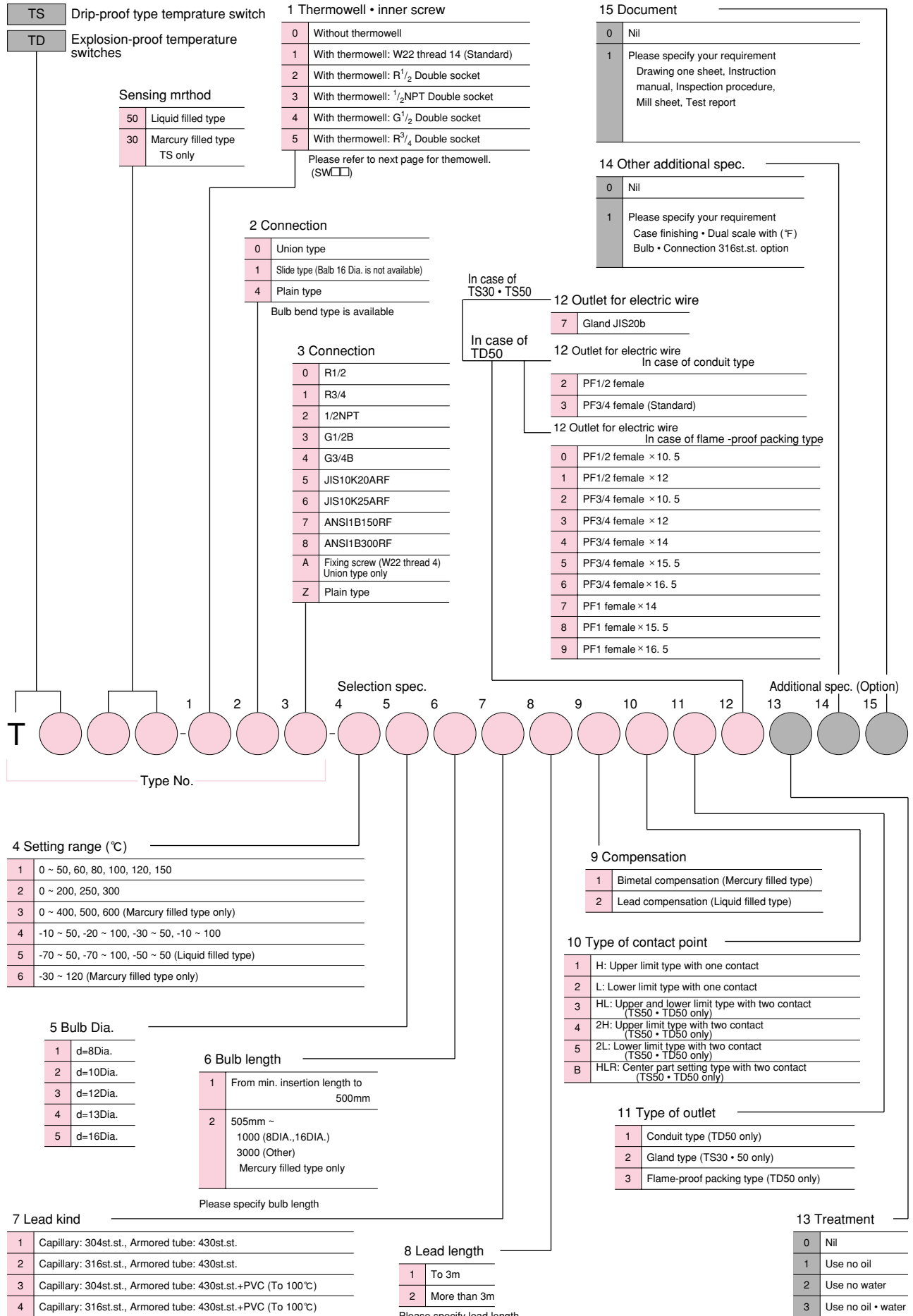

* When placing an order, check to confirm the specifications including a model, setting range, bulb, a lead parts, etc. and then select a model number.

THERMOWELL SPECIFICATION

■ Connection parts and dimension

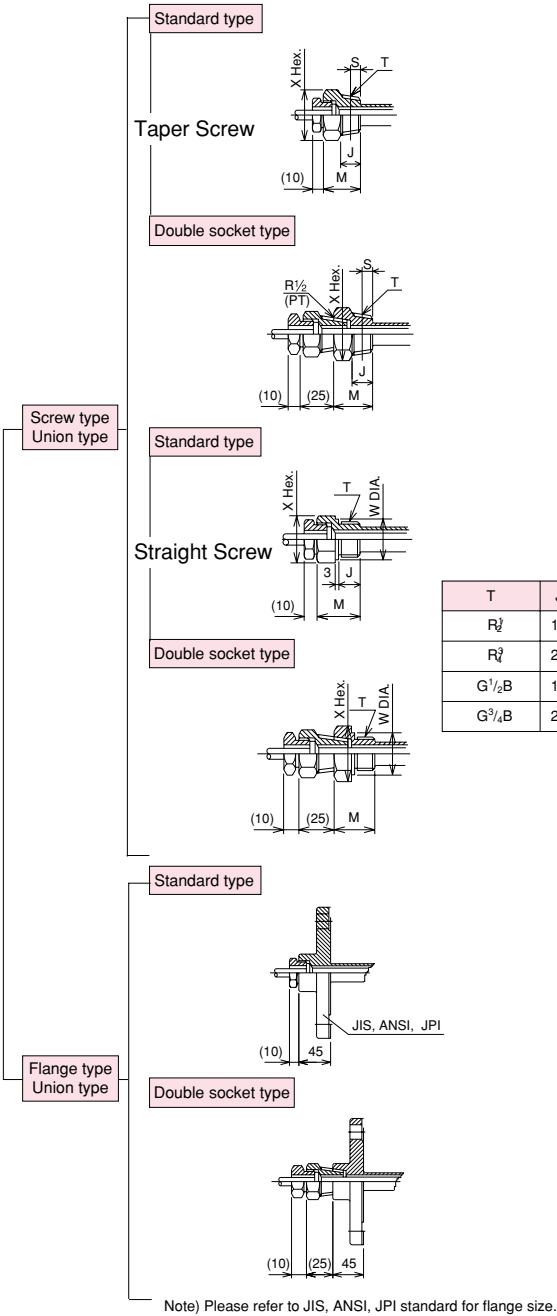

(mm)

T	J	S	W	X	M
R $\frac{1}{2}$	18	8	-	27 × 31.2	43
R $\frac{3}{4}$	20	9.5	-	30 × 34.6	45
G $\frac{1}{2}$ B	18	-	32	32 × 37	43
G $\frac{3}{4}$ B	20	-	36	36 × 41.6	45

■ Thermowell type, Size

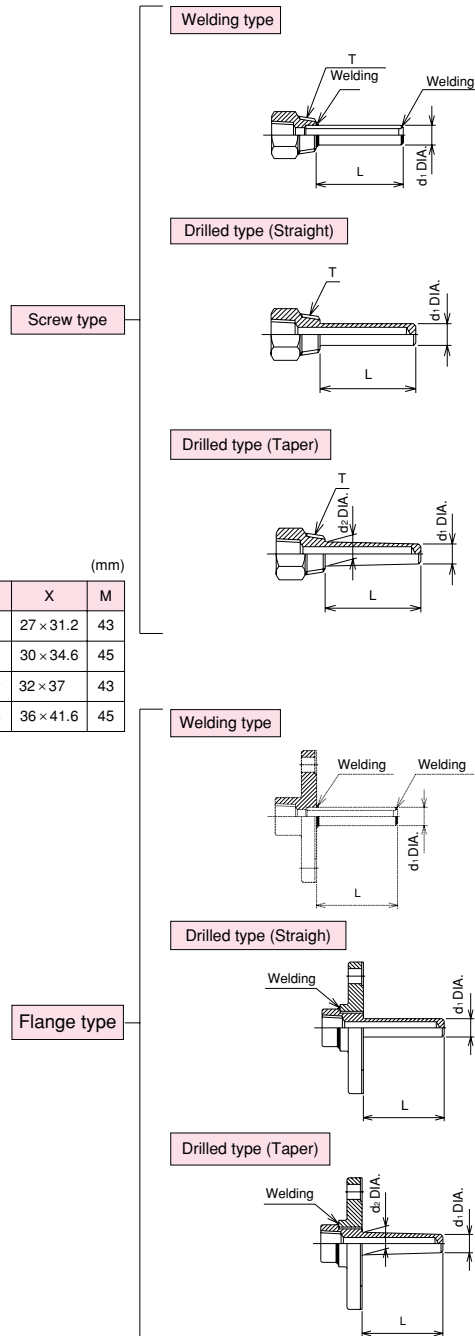

■ Relation of Thermowell and bulb.

Thermo-well	type	12		15		19		23, 19/23 (Taper)
		Drilled type	Welding type	Drilled type	Welding type	Drilled type	Welding type	Welding type
	Inner dia (d.DIA.)	8.5	8.5	10.5	11	13.5	13.5	13.5
Bulb	d DIA.	8	8	10	10	13	13	13

■ Thermowell material 1

304 st.st., 316 st.st., 316 L st.st., Titanium, Hastelloy-B, and Monel-metal are available.
Coating is available with followings. Rubber, Kel-F, Teflon, Lead or Glass
Thermowell with coating is flange type only.

■ Relation of Thermowell DIA. and connection

Out dia (d.)	Mounting	Thermowell		
		Screw (T)		Flange JIS, ANSI, JPI
		$\frac{1}{2}$	$\frac{3}{4}$	
12 DIA.	Drilled type	○	○	○
	Welding type	○	○	○
15 DIA.	Drilled type	○	○	○
	Welding type	○	○	○
19 DIA.	Drilled type	-	○	○
	Welding type	-	○	○
23 DIA.	Drilled type	-	○	○
	19 DIA./23 DIA. (Taper)	-	○	○

Standard Inner connection (connection with thermometer) is W22 thread 14 or Rc1/2

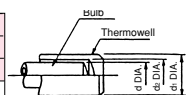

Type No. Constitution Please specify Type No., each specification and temperature range when ordering.

(Note: For this Model, there is no applicable item for the figures X, but please specify X when ordering.)

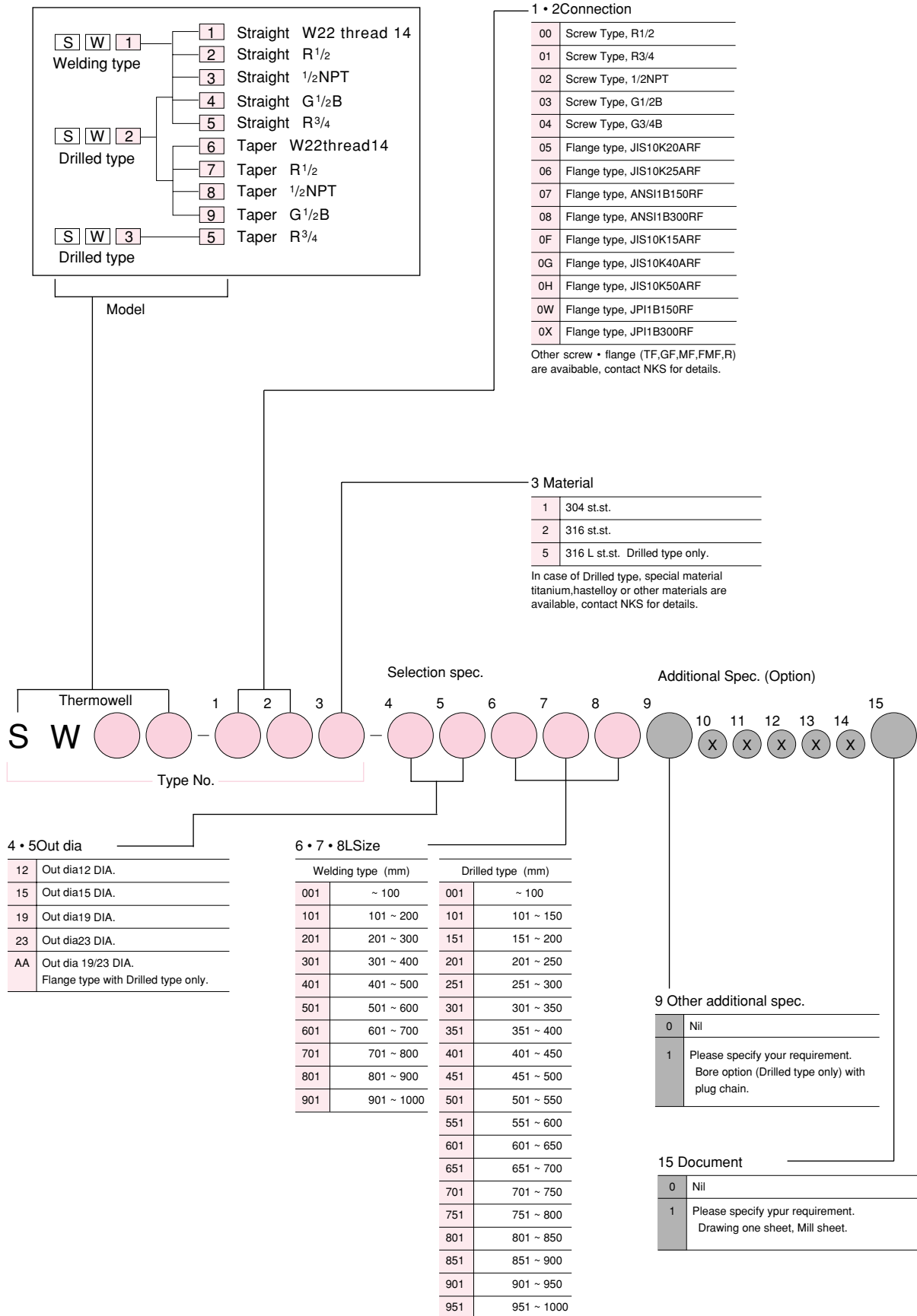

• Please specify L size.
• When required over 1000mm, please specify with 100mm steps.